

PROJECT	
ITEM #	
QUANTITY	DATE
APPROVAL	

**Short Form Specifications**

**Exterior body** is constructed of 18-gauge stainless steel side panels and 14-gauge galvanized bottom. All exterior side panels are reinforced with overlapping corners and are welded in place. All body cutouts are reinforced with 14-gauge galvanized channel supports.

**Interior Lining** at the cashier's end is 18-gauge stainless steel, with a stainless steel bottom shelf. Unit has an 16.5" x 16.5" x 5" (42cm x 42cm x 12.7cm) stainless steel cash drawer with lock and key.

**Exterior top** is constructed of 14-gauge stainless steel, welded, ground and polished into one integral unit. Top is fabricated with square exterior corners. A 2" (5.1cm) ferruled hole is located at the rear of the top to allow cord access for cash registers.

**Casters;** unit is mounted on 5" (12.7cm) diameter swivel casters with non-marking polyolefin tires and plate brakes. Overall height of caster assembly is 6" (15.2cm).



**Model SCS-30**

shown with options A, and Q

**Optional Accessories and Modifications**

- A) 12" (30.5cm) wide stainless steel fold-down tray slide
  - C) 10" (25.4cm) wide three-bar fold-down tray slide
  - D) 10" (25.4cm) wide composite fold-down cutting boards
  - E) 10" (25.4cm) wide stainless steel fold-down work shelf
  - F) Line-up interlock device
  - Q) \*120V/60Hz/1Ø, 10 amp convenience outlet with breaker
  - ST) Stainless steel trim strips
  - U) 14" x 30" (35.6cm x 76.2cm) stainless steel end drop shelf
  - V) 6" (15.2cm) high adjustable stainless steel legs in lieu of casters
  - X) Laminate exterior panels in lieu of stainless steel exterior panels
- \*Inclusion of these options will alter the electrical specifications of unit.

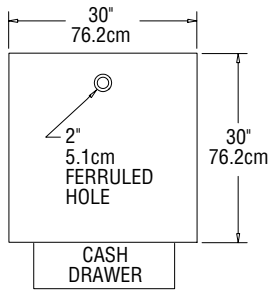
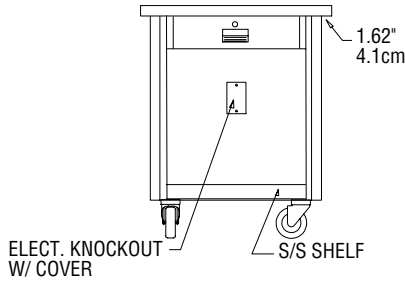
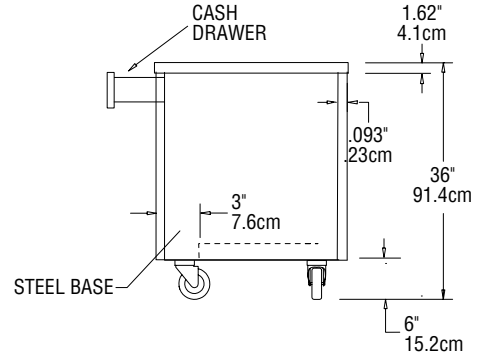
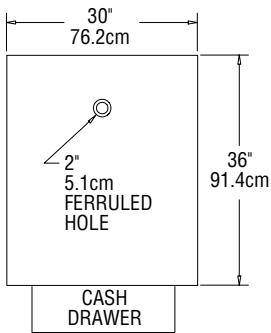
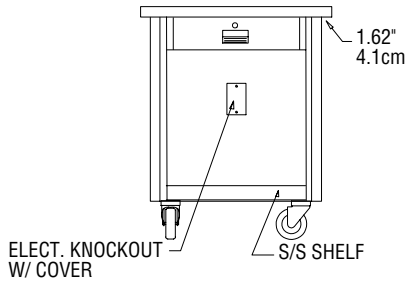
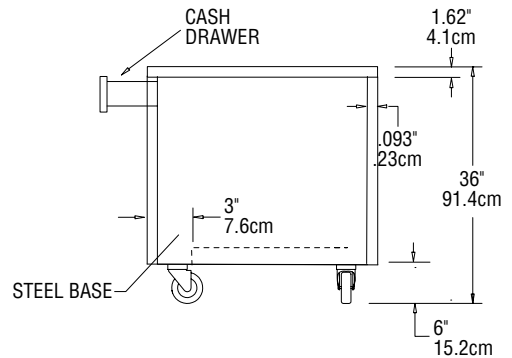
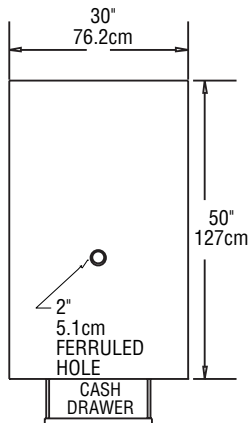
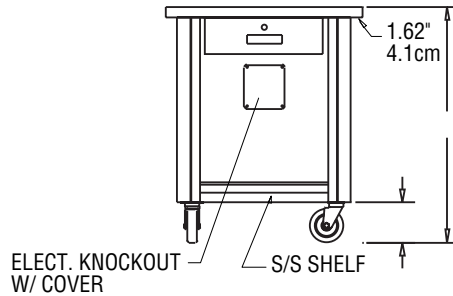
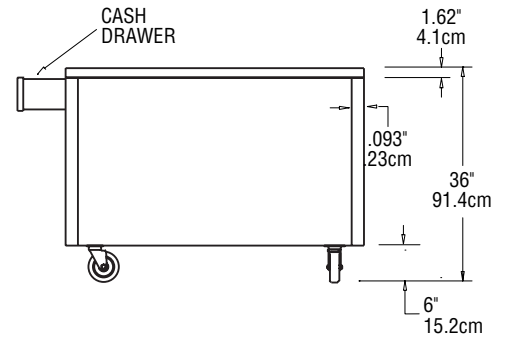

**PLAN VIEW  
SCS-30**

**ELEVATION VIEW  
SCS-30**

**END VIEW  
SCS-30**

**PLAN VIEW  
SCS-36**

**ELEVATION VIEW  
SCS-36**

**END VIEW  
SCS-36**

**PLAN VIEW  
SCS-50**

**ELEVATION VIEW  
SCS-50**

**END VIEW  
SCS-50**

### Mechanical Data—Standard Unit

MODEL NUMBER	SHIP WEIGHT
<b>SCS-30</b>	180 lbs
<b>SCS-36</b>	210 lbs
<b>SCS-50</b>	270 lbs