



PROJECT	
ITEM #	
QUANTITY	DATE
APPROVAL	

# CAB4

## Mobile enclosed four-stack dish dispensers

### Short form specifications

Cabinet top shall be 16-gauge stainless steel with all corners welded and polished and reinforced with heavy-gauge channels. Cabinet exterior panels and corner support angles shall be 20-gauge stainless steel. Unit shall have four 4.00" (10.2cm) diameter polyolefin swivel casters, and non-marking gray bumpers at each corner.

Dispenser tube shall have 3 vertical side channels and a bottom brace of 22-gauge stainless steel. Top supporting flange shall be 18-gauge stainless steel. Flange, channels and bottom brace shall be integrally welded together. Flange shall have 3 guide posts molded from high impact plastic.

Self-leveling mechanisms shall be field adjustable by adding or removing stainless steel extension springs on perimeter of vertical side channels. The dish carrier head shall be stainless steel welded rods with a removable 18-gauge stainless steel top plate.

Capacity of tubes shall be approximately 72 dishes, with a maximum stacking height of 24.00" (61.0cm).

**NOTE:** Models without "-ET" or "-QT" suffix are unheated.

#### THE FOLLOWING APPLIES TO CAB4-ET EVEN TEMP HEATED DISPENSERS ONLY:

Unit shall be supplied with 9' (2.7m) cord and NEMA 6-20P plug. Electrical connections shall be 208-230 volt, 60 hertz, single phase.

Each tube shall have its own convection heating module consisting of a single 400 watt heating element and fan motor, located in the center of the interior bottom cavity. Air intake shall have a filter. Each tube shall have an adjustable thermostat inside the motor housing and an ON/OFF switch on one of the dish guide posts. Unit shall maintain temperature between 120°F–140°F (49°C–60°C).

#### THE FOLLOWING APPLIES TO CAB4-QT QUICK TEMP HEATED DISPENSERS ONLY:

Unit shall be supplied with 9' (2.7m) cord and NEMA 6-20P plug. Electrical connections shall be 208-230 volt, 60 hertz, single phase.

Each tube shall have its own convection heating module consisting of a single 700 watt heating element and fan motor, located in the center of the interior bottom cavity. Air intake shall have a filter. Each tube shall have an adjustable thermostat inside the motor housing and an ON/OFF switch on one of the dish guide posts. Unit shall maintain temperature between 150°F–170°F (66°C–77°C).

Each tube shall have a stainless steel dome cover.

### Optional accessories & modifications

- Heavy-duty casters (consult factory)
- Flange-mount feet in lieu of casters
- Special dispenser tube heights
- 12" (30.5cm) dia. stainless steel dish dispenser tray (CAB4-1200, CAB4-1200-ET and CAB4-1200-QT only)
- Non-marring adjustment rods for oval dishes and various dish diameters (-813 through -1450 sizes only)
- Stainless steel cover with access to dishes (-813 through -1450 sizes only; standard on QT models)
- Stainless steel cover
- Hold-down rod for dispenser tubes
- Wrap-around bumpers (adds 1.75" [4.4cm] to overall length and depth)
- Fiberglas® panels
- Laminate panels
- Special voltages (consult factory)



Model CAB4-813



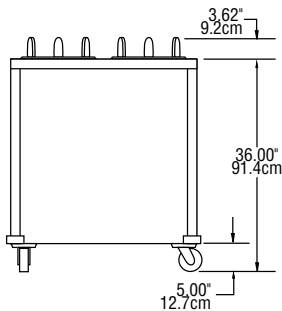
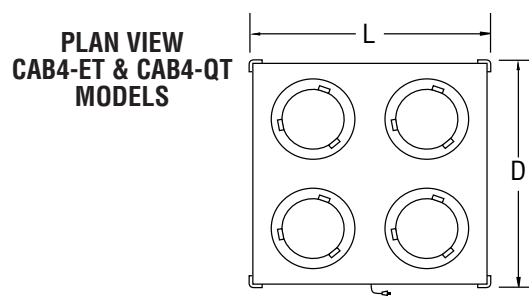
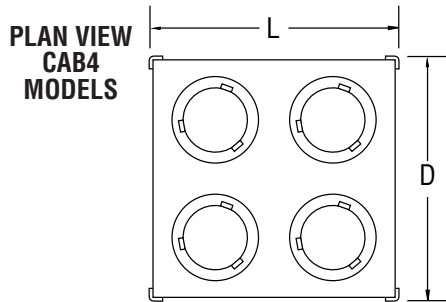

**ELEVATION VIEW  
CAB4 MODELS**

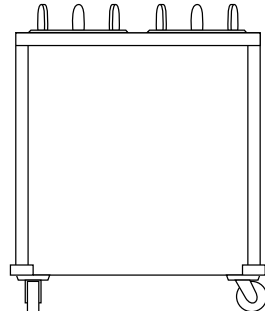

**RIGHT END VIEW  
CAB4 MODELS**

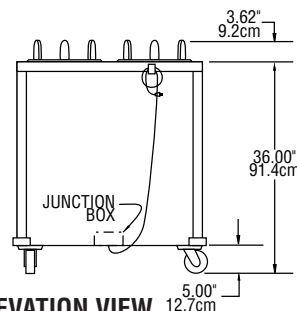

**ELEVATION VIEW  
CAB4-ET & CAB4-QT  
MODELS**

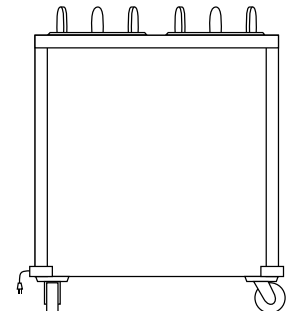

**RIGHT END VIEW  
CAB4-ET & CAB4-QT  
MODELS**

MODEL NUMBER	LENGTH	DEPTH	DISH DIAMETER RANGE	AMPS	SHIP WEIGHT
CAB4-500	27.00"/68.6cm	27.00"/68.6cm	3.00"-5.00"/7.6cm-12.7cm	NA	181 lbs/82 kg
CAB4-575	27.00"/68.6cm	27.00"/68.6cm	5.00"-5.75"/12.7cm-14.6cm	NA	185 lbs/84 kg
CAB4-650	27.00"/68.6cm	27.00"/68.6cm	5.75"-6.50"/14.6cm-16.5cm	NA	186 lbs/84 kg
CAB4-725	27.00"/68.6cm	27.00"/68.6cm	6.50"-7.25"/16.5cm-18.4cm	NA	189 lbs/86 kg
CAB4-813	32.25"/81.9cm	32.25"/81.9cm	7.25"-8.12"/18.4cm-20.6cm	NA	213 lbs/97 kg
CAB4-913	32.25"/81.9cm	32.25"/81.9cm	8.12"-9.12"/20.6cm-23.2cm	NA	217 lbs/98 kg
CAB4-1013	32.25"/81.9cm	32.25"/81.9cm	9.12"-10.12"/23.2cm-25.7cm	NA	221 lbs/100 kg
CAB4-1200	36.00"/91.4cm	36.00"/91.4cm	10.12"-12.00"/25.7cm-30.5cm	NA	240 lbs/109 kg
CAB4-1450	42.00"/106.7cm	42.00"/106.7cm	12.00"-14.50"/30.5cm-36.8cm	NA	263 lbs/119 kg
CAB4-500ET	27.00"/68.6cm	27.00"/68.6cm	3.00"-5.00"/7.6cm-12.7cm	17.0	226 lbs/103 kg
CAB4-575ET	27.00"/68.6cm	27.00"/68.6cm	5.00"-5.75"/12.7cm-14.6cm	17.0	230 lbs/104 kg
CAB4-650ET	27.00"/68.6cm	27.00"/68.6cm	5.75"-6.50"/14.6cm-16.5cm	17.0	234 lbs/106 kg
CAB4-725ET	27.00"/68.6cm	27.00"/68.6cm	6.50"-7.25"/16.5cm-18.4cm	17.0	242 lbs/110 kg
CAB4-813ET	32.25"/81.9cm	32.25"/81.9cm	7.25"-8.12"/18.4cm-20.6cm	17.0	270 lbs/123 kg
CAB4-913ET	32.25"/81.9cm	32.25"/81.9cm	8.12"-9.12"/20.6cm-23.2cm	17.0	278 lbs/126 kg
CAB4-1013ET	32.25"/81.9cm	32.25"/81.9cm	9.12"-10.12"/23.2cm-25.7cm	17.0	286 lbs/130 kg
CAB4-1200ET	36.00"/91.4cm	36.00"/91.4cm	10.12"-12.00"/25.7cm-30.5cm	17.0	313 lbs/142 kg
CAB4-1450ET	42.00"/106.7cm	42.00"/106.7cm	12.00"-14.50"/30.5cm-36.8cm	17.0	337 lbs/153 kg
CAB4-813QT	32.25"/81.9cm	32.25"/81.9cm	7.25"-8.12"/18.4cm-20.6cm	17.0	290 lbs/132 kg
CAB4-913QT	32.25"/81.9cm	32.25"/81.9cm	8.12"-9.12"/20.6cm-23.2cm	17.0	298 lbs/135 kg
CAB4-1013QT	32.25"/81.9cm	32.25"/81.9cm	9.12"-10.12"/23.2cm-25.7cm	17.0	306 lbs/139 kg
CAB4-1200QT	36.00"/91.4cm	36.00"/91.4cm	10.12"-12.00"/25.7cm-30.5cm	17.0	333 lbs/151 kg
CAB4-1450QT	42.00"/106.7cm	42.00"/106.7cm	12.00"-14.50"/30.5cm-36.8cm	17.0	351 lbs/159 kg

**NOTES**

- CAB4-ET models are 208-230 volt, 60 hertz, single phase, and include a 9' (2.7m) cord with NEMA 6-20P plug. CAB4-QT models are 208-230volt, 60 hertz, single phase, and include a 9' (2.7m) cord with NEMA 6-20P plug.
- Optional adjusting rods (available on 813-1450 models only) reduce the maximum round dish diameter by 1.25" (3.2cm); overall adjustment by rods is 1.50" (3.8cm). Must be ordered for each individual dispenser tube, non-marring adjustment rods, installed at factory only.