



PROJECT	
ITEM #	
QUANTITY	DATE
APPROVAL	

# CAB3

## Mobile enclosed three-stack dish dispensers

### Short form specifications

Cabinet top shall be 16-gauge stainless steel with all corners welded and polished and reinforced with heavy-gauge channels. Cabinet exterior panels and corner support angles shall be 20-gauge stainless steel. Unit shall have four 4.00" (10.2cm) diameter polyolefin swivel casters (all locking), and non-marking gray bumpers at each corner.

Dispenser tube shall have 3 vertical side channels and a bottom brace of 22-gauge stainless steel. Top supporting flange shall be 18-gauge stainless steel. Flange, channels and bottom brace shall be integrally welded together. Flange shall have 3 guide posts molded from high impact plastic.

Self-leveling mechanisms shall be field adjustable by adding or removing stainless steel extension springs on perimeter of vertical side channels. The dish carrier head shall be stainless steel welded rods with a removable 18-gauge stainless steel top plate.

Capacity of tubes shall be approximately 72 dishes, with a maximum stacking height of 24.00" (61.0cm).

**NOTE:** Models without "-ET" or "-QT" suffix are unheated.

#### THE FOLLOWING APPLIES TO CAB3-ET EVEN TEMP HEATED DISPENSERS ONLY:

Unit shall be supplied with 9' (2.7m) cord and NEMA 5-20P plug. Electrical connections shall be 120 volt, 60 hertz, single phase.

Each tube shall have its own convection heating module consisting of a single 400 watt heating element and fan motor, located in the center of the interior bottom cavity. Air intake shall have a filter. Each tube shall have an adjustable thermostat inside the motor housing and an ON/OFF switch on one of the dish guide posts. Unit shall maintain temperature between 120°F–140°F (49°C–60°C).

#### THE FOLLOWING APPLIES TO CAB3-QT QUICK TEMP HEATED DISPENSERS ONLY:

Unit shall be supplied with 9' (2.7m) cord and NEMA 6-20P plug. Electrical connections shall be 208-230 volt, 60 hertz, single phase.

Each tube shall have its own convection heating module consisting of a single 700 watt heating element and fan motor, located in the center of the interior bottom cavity. Air intake shall have a filter. Each tube shall have an adjustable thermostat inside the motor housing and an ON/OFF switch on one of the dish guide posts. Unit shall maintain temperature between 150°F–170°F (66°C–77°C).

Each tube shall have a stainless steel cover.

### Optional accessories & modifications

- Heavy-duty casters (consult factory)
- Flange-mount feet in lieu of casters
- Special dispenser tube heights
- 12" (30.5cm) dia. stainless steel dish dispenser tray (CAB3-1200, CAB3-1200-ET and CAB3-1200-QT only)
- Non-marring adjustment rods for oval dishes and various dish diameters (-813 through -1450 sizes only)
- Stainless steel cover with access to dishes (-813 through -1450 sizes only; standard on QT models)
- Stainless steel tube cover
- Hold-down rod for dispenser tubes
- Wrap-around bumpers (adds 1.75" [4.4cm] to overall length and depth)
- Fiberglas® panels
- Laminate panels
- Special voltages (consult factory)

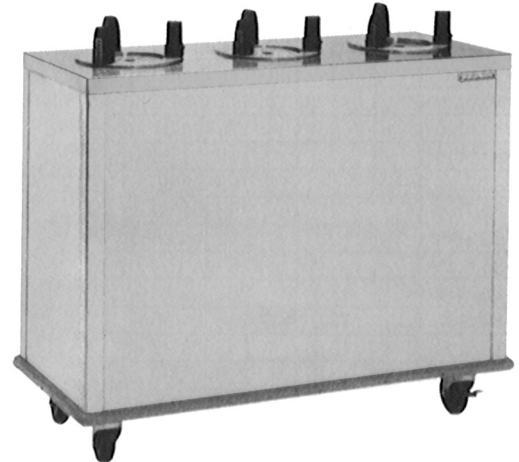

**Model CAB3-575**  
with optional wrap-around bumpers



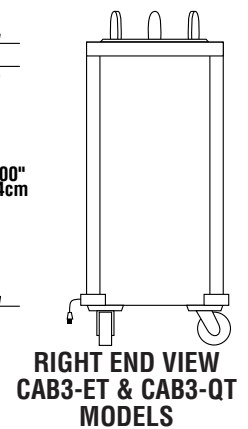
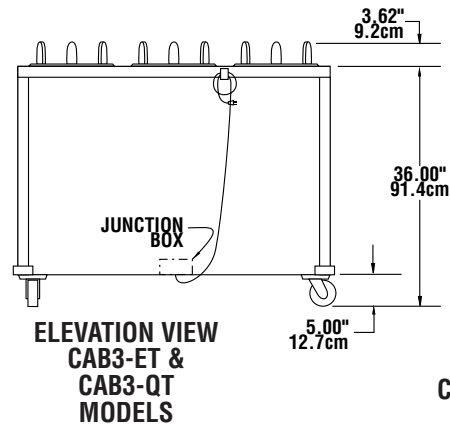
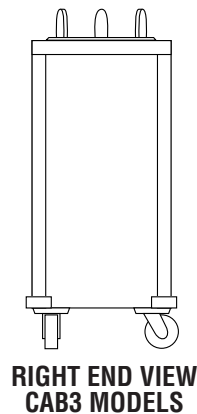
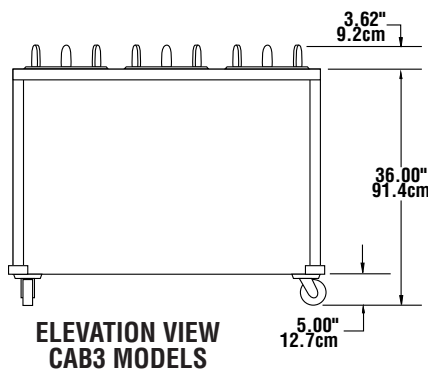
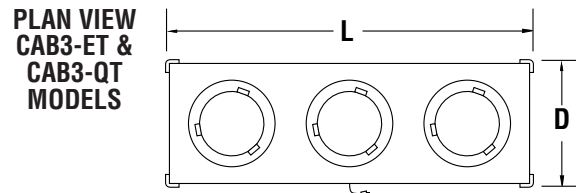
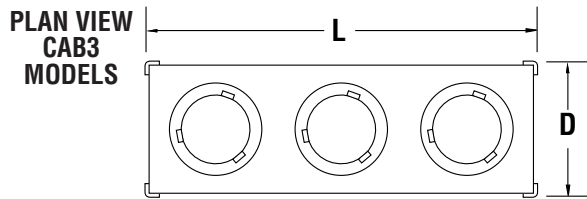

MODEL NUMBER	LENGTH	DEPTH	DISH DIAMETER RANGE	AMPS	SHIP WEIGHT
CAB3-500	41.25"/104.8cm	17.00"/43.2cm	3.00"-5.00"/7.6cm-12.7cm	NA	173 lbs/79 kg
CAB3-575	41.25"/104.8cm	17.00"/43.2cm	5.00"-5.75"/12.7cm-14.6cm	NA	176 lbs/80 kg
CAB3-650	41.25"/104.8cm	17.00"/43.2cm	5.75"-6.50"/14.6cm-16.5cm	NA	177 lbs/80 kg
CAB3-725	41.25"/104.8cm	17.00"/43.2cm	6.50"-7.25"/16.5cm-18.4cm	NA	179 lbs/81 kg
CAB3-813	47.25"/120.0cm	17.00"/43.2cm	7.25"-8.12"/18.4cm-20.6cm	NA	190 lbs/86 kg
CAB3-913	47.25"/120.0cm	17.00"/43.2cm	8.12"-9.12"/20.6cm-23.2cm	NA	193 lbs/88 kg
CAB3-1013	47.25"/120.0cm	17.00"/43.2cm	9.12"-10.12"/23.2cm-25.7cm	NA	196 lbs/89 kg
CAB3-1200	53.25"/135.3cm	19.00"/48.3cm	10.12"-12.00"/25.7cm-30.5cm	NA	212 lbs/96 kg
CAB3-1450	62.00"/157.5cm	21.50"/54.6cm	12.00"-14.50"/30.5cm-36.8cm	NA	229 lbs/104 kg
CAB3-500ET	41.25"/104.8cm	17.00"/43.2cm	3.00"-5.00"/7.6cm-12.7cm	13.0	207 lbs/94 kg
CAB3-575ET	41.25"/104.8cm	17.00"/43.2cm	5.00"-5.75"/12.7cm-14.6cm	13.0	210 lbs/95 kg
CAB3-650ET	41.25"/104.8cm	17.00"/43.2cm	5.75"-6.50"/14.6cm-16.5cm	13.0	213 lbs/97 kg
CAB3-725ET	41.25"/104.8cm	17.00"/43.2cm	6.50"-7.25"/16.5cm-18.4cm	13.0	219 lbs/99 kg
CAB3-813ET	47.25"/120.0cm	17.00"/43.2cm	7.25"-8.12"/18.4cm-20.6cm	13.0	233 lbs/106 kg
CAB3-913ET	47.25"/120.0cm	17.00"/43.2cm	8.12"-9.12"/20.6cm-23.2cm	13.0	239 lbs/108 kg
CAB3-1013ET	47.25"/120.0cm	17.00"/43.2cm	9.12"-10.12"/23.2cm-25.7cm	13.0	245 lbs/111 kg
CAB3-1200ET	53.25"/135.3cm	19.00"/48.3cm	10.12"-12.00"/25.7cm-30.5cm	13.0	262 lbs/119 kg
CAB3-1450ET	62.00"/157.5cm	21.50"/54.6cm	12.00"-14.50"/30.5cm-36.8cm	13.0	277 lbs/126 kg
CAB3-813QT	47.25"/120.0cm	17.00"/43.2cm	7.25"-8.12"/18.4cm-20.6cm	13.0	243 lbs/110 kg
CAB3-913QT	47.25"/120.0cm	17.00"/43.2cm	8.12"-9.12"/20.6cm-23.2cm	13.0	249 lbs/113 kg
CAB3-1013QT	47.25"/120.0cm	17.00"/43.2cm	9.12"-10.12"/23.2cm-25.7cm	13.0	255 lbs/116 kg
CAB3-1200QT	53.25"/135.3cm	19.00"/48.3cm	10.12"-12.00"/25.7cm-30.5cm	13.0	272 lbs/123 kg
CAB3-1450QT	62.00"/157.5cm	21.50"/54.6cm	12.00"-14.50"/30.5cm-36.8cm	13.0	287 lbs/130 kg

### NOTES

- CAB3-ET models are 120 volt, 60 hertz, single phase, and include a 9' (2.7m) cord with NEMA 5-20P plug. CAB3-QT models are 208-230 volt, 60 hertz, single phase, and include a 9' (2.7m) cord with NEMA 6-20P plug.
- Optional adjusting rods (available on 813-1450 models only) reduce the maximum round dish diameter by 1.25" (3.2cm); overall adjustment by rods is 1.50" (3.8cm). Non-marking adjustment rods must be ordered for each individual dispenser tube; installed at factory only.