



PROJECT	
ITEM #	
QUANTITY	DATE
APPROVAL	

CAB2

Mobile enclosed two-stack dish dispensers

Short form specifications

Cabinet top shall be 16-gauge stainless steel with all corners welded and polished and reinforced with heavy-gauge channels. Cabinet exterior panels and corner support angles shall be 20-gauge stainless steel. Unit shall have four 4.00" (10.2cm) diameter polyolefin swivel casters (all locking), and non-marking gray bumpers at each corner.

Dispenser tube shall have 3 vertical side channels and a bottom brace of 22-gauge stainless steel. Top supporting flange shall be 18-gauge stainless steel. Flange, channels and bottom brace shall be integrally welded together. Flange shall have 3 guide posts molded from high impact plastic.

Self-leveling mechanisms shall be field adjustable by adding or removing stainless steel extension springs on perimeter of vertical side channels. The dish carrier head shall be stainless steel welded rods with a removable 18-gauge stainless steel top plate.

Capacity of tubes shall be approximately 72 dishes, with a maximum stacking height of 24.00" (61.0cm).

NOTE: Models without "-ET" or "-QT" suffix are unheated.

THE FOLLOWING APPLIES TO CAB2-ET EVEN TEMP HEATED DISPENSERS ONLY:

Unit shall be supplied with 9' (2.7m) cord and NEMA 5-15P plug. Electrical connections shall be 120 volt, 60 hertz, single phase.

Each tube shall have its own convection heating module consisting of a single 400 watt heating element and fan motor, located in the center of the interior bottom cavity. Air intake shall have a filter. Each tube shall have an adjustable thermostat inside the motor housing and an ON/OFF switch on one of the dish guide posts. Unit shall maintain temperature between 120°F–140°F (49°C–60°C).

THE FOLLOWING APPLIES TO CAB2-QT QUICK TEMP HEATED DISPENSERS ONLY:

Unit shall be supplied with 9' (2.7m) cord and NEMA 5-20P plug. Electrical connections shall be 120 volt, 60 hertz, single phase.

Each tube shall have its own convection heating module consisting of a single 700 watt heating element and fan motor, located in the center of the interior bottom cavity. Air intake shall have a filter. Each tube shall have an adjustable thermostat inside the motor housing and an ON/OFF switch on one of the dish guide posts. Unit shall maintain temperature between 150°F–170°F (66°C–77°C).

Each tube shall have a stainless steel cover.



Model CAB2-913

Optional accessories & modifications

- Heavy-duty casters (consult factory)
- Flange-mount feet in lieu of casters
- Special dispenser tube heights
- 12" (30.5cm) dia. stainless steel dish dispenser tray (CAB2-1200, CAB2-1200-ET and CAB2-1200-QT only)
- Non-marring adjustment rods for oval dishes and various dish diameters (-813 through -1450 sizes only)
- Stainless steel cover with access to dishes (-813 through -1450 sizes only; standard on QT models)
- Stainless steel tube cover
- Hold-down rod for dispenser tubes
- Wrap-around bumpers (adds 1.75" [4.4cm] to overall length and depth)
- Fiberglas® panels
- Laminate panels
- Special voltages (consult factory)



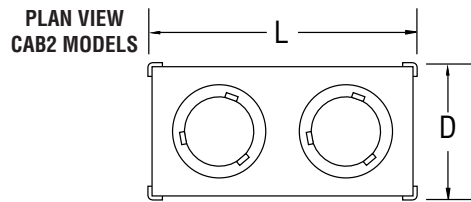

PLAN VIEW
CAB2-ET & CAB2-QT MODELS

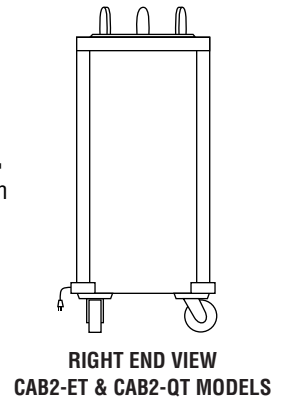
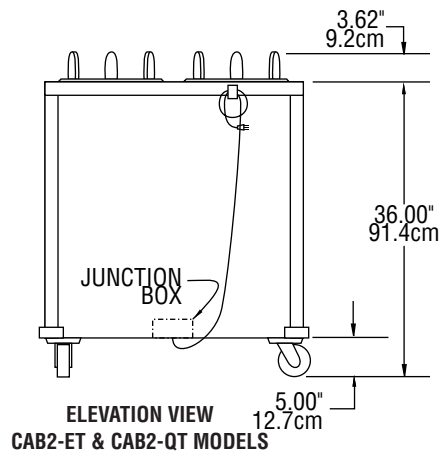
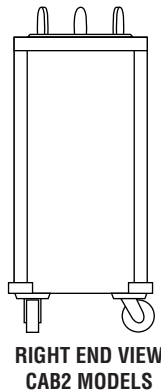
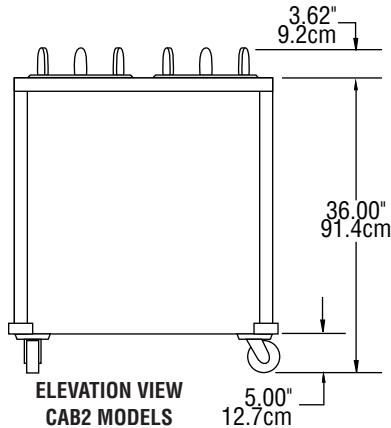
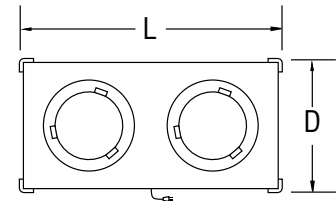

MODEL NUMBER	LENGTH	DEPTH	DISH DIAMETER RANGE	AMPS	SHIP WEIGHT
CAB2-500	28.25"/71.8cm	17.00"/43.2cm	3.00"-5.00"/7.6cm-12.7cm	NA	125 lbs/57 kg
CAB2-575	28.25"/71.8cm	17.00"/43.2cm	5.00"-5.75"/12.7cm-14.6cm	NA	125 lbs/57 kg
CAB2-650	28.25"/71.8cm	17.00"/43.2cm	5.75"-6.50"/14.6cm-16.5cm	NA	127 lbs/58 kg
CAB2-725	28.25"/71.8cm	17.00"/43.2cm	6.50"-7.25"/16.5cm-18.4cm	NA	130 lbs/59 kg
CAB2-813	32.25"/81.9cm	17.00"/43.2cm	7.25"-8.12"/18.4cm-20.6cm	NA	132 lbs/60 kg
CAB2-913	32.25"/81.9cm	17.00"/43.2cm	8.12"-9.12"/20.6cm-23.2cm	NA	135 lbs/61 kg
CAB2-1013	32.25"/81.9cm	17.00"/43.2cm	9.12"-10.12"/23.2cm-25.7cm	NA	142 lbs/64 kg
CAB2-1200	37.00"/94.0cm	19.00"/48.3cm	10.12"-12.00"/25.7cm-30.5cm	NA	160 lbs/73 kg
CAB2-1450	42.00"/106.7cm	21.50"/54.6cm	12.00"-14.50"/30.5cm-36.8cm	NA	176 lbs/80 kg
CAB2-500ET	28.25"/71.8cm	17.00"/43.2cm	3.00"-5.00"/7.6cm-12.7cm	9.0	144 lbs/65 kg
CAB2-575ET	28.25"/71.8cm	17.00"/43.2cm	5.00"-5.75"/12.7cm-14.6cm	9.0	146 lbs/66 kg
CAB2-650ET	28.25"/71.8cm	17.00"/43.2cm	5.75"-6.50"/14.6cm-16.5cm	9.0	148 lbs/67 kg
CAB2-725ET	28.25"/71.8cm	17.00"/43.2cm	6.50"-7.25"/16.5cm-18.4cm	9.0	152 lbs/69 kg
CAB2-813ET	32.25"/81.9cm	17.00"/43.2cm	7.25"-8.12"/18.4cm-20.6cm	9.0	160 lbs/73 kg
CAB2-913ET	32.25"/81.9cm	17.00"/43.2cm	8.12"-9.12"/20.6cm-23.2cm	9.0	168 lbs/76 kg
CAB2-1013ET	32.25"/81.9cm	17.00"/43.2cm	9.12"-10.12"/23.2cm-25.7cm	9.0	171 lbs/78 kg
CAB2-1200ET	37.00"/94.0cm	19.00"/48.3cm	10.12"-12.00"/25.7cm-30.5cm	9.0	192 lbs/87 kg
CAB2-1450ET	42.00"/106.7cm	21.50"/54.6cm	12.00"-14.50"/30.5cm-36.8cm	9.0	201 lbs/91 kg
CAB2-813QT	32.25"/81.9cm	17.00"/43.2cm	7.25"-8.12"/18.4cm-20.6cm	15.0	161 lbs/73 kg
CAB2-913QT	32.25"/81.9cm	17.00"/43.2cm	8.12"-9.12"/20.6cm-23.2cm	15.0	166 lbs/75 kg
CAB2-1013QT	32.25"/81.9cm	17.00"/43.2cm	9.12"-10.12"/23.2cm-25.7cm	15.0	169 lbs/77 kg
CAB2-1200QT	37.00"/94.0cm	19.00"/48.3cm	10.12"-12.00"/25.7cm-30.5cm	15.0	186 lbs/84 kg
CAB2-1450QT	42.00"/106.7cm	21.50"/54.6cm	12.00"-14.50"/30.5cm-36.8cm	15.0	201 lbs/91 kg

NOTES

- CAB2-ET models are 120 volt, 60 hertz, single phase, and include a 9' (2.7m) cord with NEMA 5-15P plug. CAB2-QT models are 120 volt, 60 hertz, single phase, and include a 9' (2.7m) cord with NEMA 5-20P plug.
- Optional adjusting rods (available on 813-1450 models only) reduce the maximum round dish diameter by 1.25" (3.2cm); overall adjustment by rods is 1.50" (3.8cm). Non-marking adjustment rods must be ordered for each individual dispenser tube; installed at factory only.