



PROJECT	
ITEM #	
QUANTITY	DATE
APPROVAL	

## 4460N-M/D4460N-M

### Front-Breathing Self-Contained Compact MegaTop Refrigerators

#### Short Form Specifications

**Exterior top** is one-piece 22-gauge stainless steel with integral 2.12" (5.1cm) square nosing on the front. Telescoping lid is constructed of 20-gauge stainless steel. Top opening can accept 12, 18 or 24 1/6 size plastic pans 4"-6" (10.1cm-15.2cm) deep. Adapter bars and 1/6 size pans are supplied by Delfield. Temperature in top openings maintains 33°F (1°C) to 41°F (5°C), with pans recessed 2.5" (6.4cm) at 86°F ambient room temperature, meeting NSF 7 requirements. One 60" x 8" x .5" (152.4cm x 20.3cm x 1.3cm) plastic cutting board is mounted on the top at the front edge.

**Exterior back and bottom** are two-piece 24-gauge galvanized steel. Exterior ends are stainless steel.

**Interior sides** are thermoformed ABS plastic with shelf supports. Base is fully insulated with high-density foamed in place polyurethane.

**Refrigeration** system uses HFC-404A refrigerant. Compressor is 1/2 H.P., with condenser coil and hot gas condensate evaporator mounted on rear of the cabinet. Evaporator coils and temperature control are located on the interior rear wall of the cabinet. Refrigerant flow is controlled by a capillary tube. Cabinet maintains an interior cabinet temperature of 36°F to 40°F (2°C to 4°C).

**Electrical connections** are 115 volt, 60 Hertz, single phase. Unit has an 8' (2.4m) long electrical cord and NEMA 5-15P plug.

**Casters:** Equipment is mounted on 2" (5.08cm) diameter plate casters with front two locking. Equipment clearance above the floor is 2.5" (6.35cm).

**Doors** have a 22-gauge stainless steel exterior, with thermoformed ABS plastic interior liner. Cabinet has one adjustable epoxy-coated wire shelf per door opening.

**Drawers** have 22-gauge stainless steel exterior with thermoformed ABS plastic interior liner. Drawer frames are 14-gauge stainless steel. Drawer slides are 14-gauge stainless steel with stainless steel bearings. Each top drawer holds one 12" x 20" (30.5cm x 50.8cm) pan 4" -6" (10.1cm-15.2cm) deep. Each bottom drawer holds one 12" x 20" (30.5cm x 50.8cm) pan 4" (10.1cm) deep. Pans are supplied by others.

#### Optional Accessories and Modifications

- Flat lift off covers
  - 4" x 2" stainless steel backsplash
  - 18" wide single tier overshelf
  - Stainless steel finish on back
  - Plastic laminate on front
  - Additional wire shelves
  - Door lock
  - \*220V/50 Hertz electrical system
- \*Inclusion of this option will alter electrical specifications of the unit.

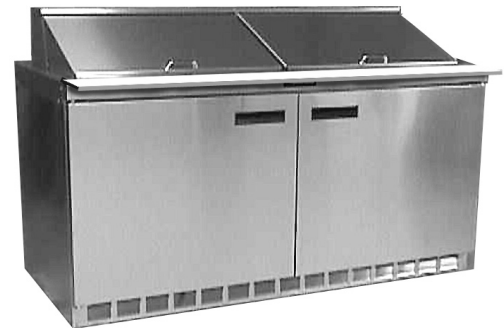

Model 4460N-24M



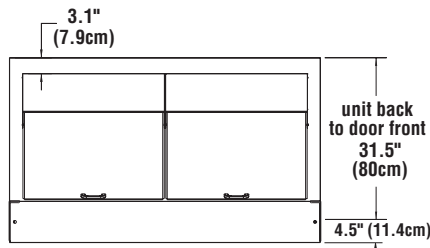

**PLAN VIEW  
ALL MODELS**

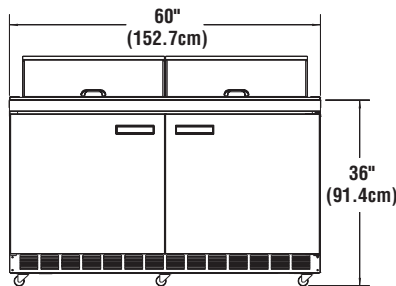

**ELEVATION VIEW  
ALL DOOR MODELS**

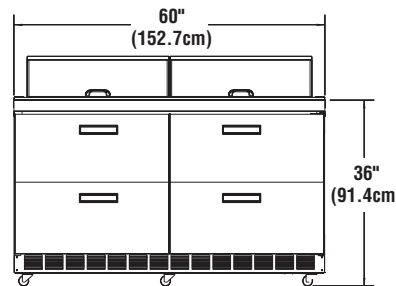

**ELEVATION VIEW  
ALL DRAWER MODELS**

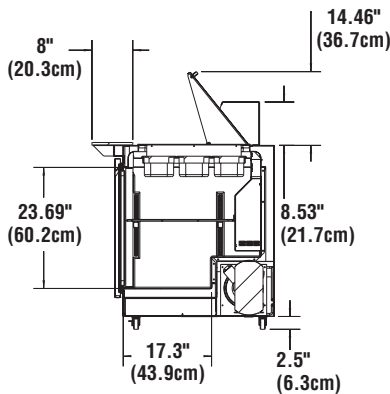

**END VIEW  
ALL DOOR MODELS**

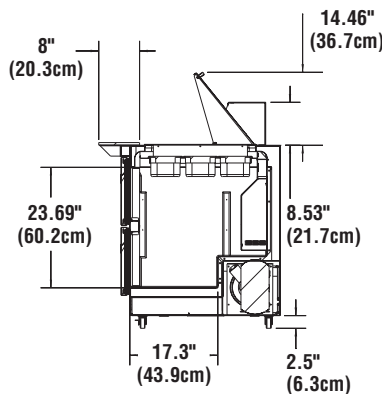

**END VIEW  
ALL DRAWER MODELS**

### 1/6 SIZE PAN CONFIGURATIONS

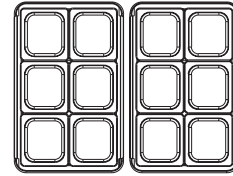

**4460N-12M/D4460N-12M**

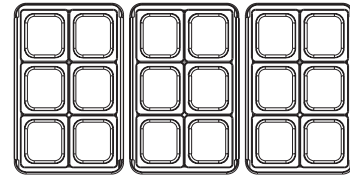

**4460N-18M/D4460N-18M**

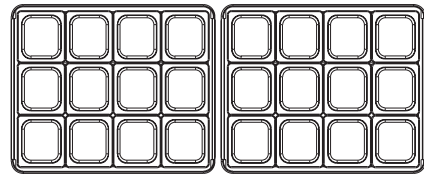

**4460N-24M/D4460N-24M**

**DRAWER CLEARANCE IS: 22.5" (57.2cm)**  
**DOOR CLEARANCE IS: 30" (76.2cm)**

**INSTALLATION NOTE:**

Refrigeration system is designed so that air will flow under the unit, through the compressor area and out the front of the unit. Any restriction to this air flow path will void the warranties.

### Mechanical Data—Standard Unit

MODEL NUMBER	1/6 SIZE PAN CAPACITY	#OF SHELVES	SHELF AREA. SQ. FT.	STORAGE CAP. CU. FT.	H.P.	VOLTS/HERTZ/ PHASE	AMPS	NEMA PLUG	SHIP WEIGHT
4460N-12M	12	2	7.36	15.7	1/2	115/60/1	12.0	5-15P	430 lbs/ 195 kg
D4460N-12M	12	N/A	N/A	2.7	1/2	115/60/1	12.0	5-15P	465 lbs/ 210 kg
4460N-18M	18	2	7.36	15.7	1/2	115/60/1	12.0	5-15P	430 lbs/ 195 kg
D4460N-18M	18	N/A	N/A	2.7	1/2	115/60/1	12.0	5-15P	465 lbs/ 210 kg
4460N-24M	24	2	7.36	15.7	1/2	115/60/1	12.0	5-15P	430 lbs/ 195 kg
D4460N-24M	24	N/A	N/A	2.7	1/2	115/60/1	12.0	5-15P	465 lbs/ 210 kg