



|          |      |
|----------|------|
| PROJECT  |      |
| ITEM #   |      |
| QUANTITY | DATE |
| APPROVAL |      |

## 4448N-M/D4448N-M

### Front-Breathing Self-Contained Compact MegaTop Refrigerators

#### Short Form Specifications

**Exterior top** is one-piece 22-gauge stainless steel with integral 2.12" (5.1cm) square nosing on the front. Top has one telescoping cover, with three openings to accept eighteen 1/6 size plastic pans 4"-6" (10.1-15.2cm) deep or three 12" x 20" (30.5cm x 50.8cm) full size pans, 4"-6" (10.1-15.2cm) deep. Adapter bars and 1/6 size pans are supplied by Delfield. Lid is constructed of 20-gauge stainless steel. Temperature in top openings maintains 33°F (1°C) to 41°F (5°C), with pans recessed 2.5" (6.4cm) at 86°F ambient room temperature, meeting NSF 7 requirements. One 48" x 8" x .5" (121.9cm x 20.3cm x 1.3cm) plastic cutting board is mounted on the top at the front edge.

**Exterior back and bottom** are two-piece 24-gauge galvanized steel. Exterior ends are stainless steel.

**Interior sides** are thermoformed ABS plastic with integral shelf supports. Base is fully insulated with high-density foamed in place polyurethane.

**Refrigeration** system uses HFC-404A refrigerant. Compressor is 1/5 H.P., with condenser coil and hot gas condensate evaporator mounted on rear of the cabinet. Evaporator coils and temperature control are located on the interior rear wall of the cabinet. Refrigerant flow is controlled by a capillary tube. Cabinet maintains an interior cabinet temperature of 36°F to 40°F (2°C to 4°C).

**Electrical connections** are 115 volt, 60 Hertz, single phase. Unit has an 8' (2.4m) long electrical cord and NEMA 5-15P plug.

**Casters:** Equipment is mounted on 2" (5.08cm) diameter plate casters with front two locking. Equipment clearance above the floor is 2.5" (6.35cm).

**Doors** have a 22-gauge stainless steel exterior, with thermoformed ABS plastic interior liner. Cabinet has one adjustable epoxy-coated wire shelf per door opening.

**Drawers** have 22-gauge stainless steel exterior with thermoformed ABS plastic interior liner. Drawer frames are 14-gauge stainless steel. Drawer slides are 14-gauge stainless steel with stainless steel bearings. Each top drawer will hold one 12" x 20" (30.5cm x 50.8cm) pan 4" -6" (10.1cm-15.2cm) deep. Each bottom drawer holds one 12" x 20" (30.5cm x 50.8cm) pan 4" (10.1cm) deep. Pans are supplied by others.



Model 4448N-18M

#### Optional Accessories and Modifications

- Flat lift off covers
  - 18" wide single tier overshelf
  - Stainless steel finish on back
  - Plastic laminate on front
  - Additional wire shelves
  - Door lock
  - \*220V/50 Hertz electrical system
- \*Inclusion of this option will alter electrical specifications of the unit.



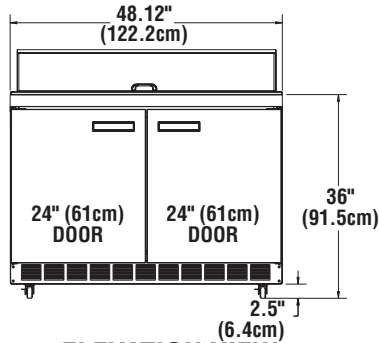

**ELEVATION VIEW  
4448N18M**

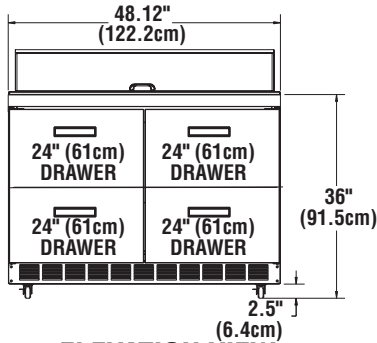

**ELEVATION VIEW  
D4448N18M**

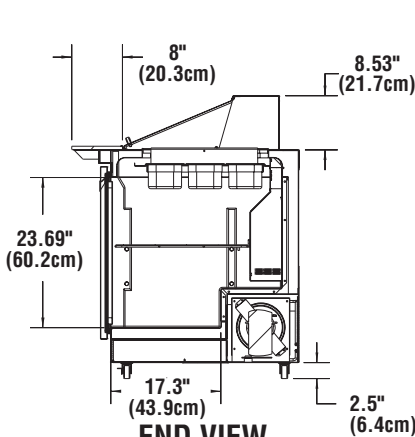

**END VIEW  
4448N18M**

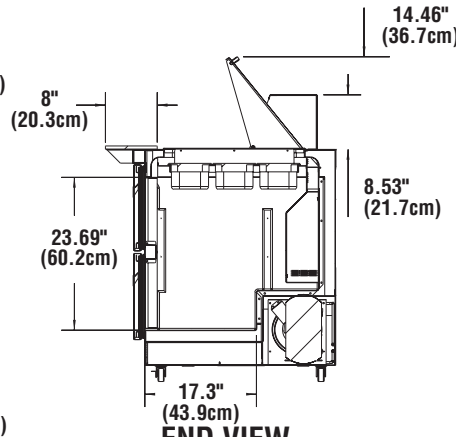

**END VIEW  
D4448N18M**

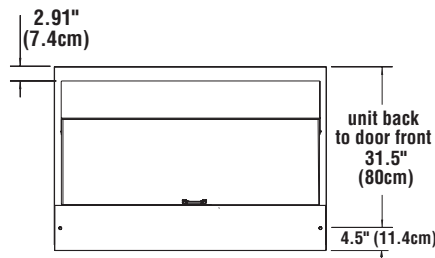

**PLAN VIEW  
ALL MODELS**

**1/6 SIZE PAN CONFIGURATION**

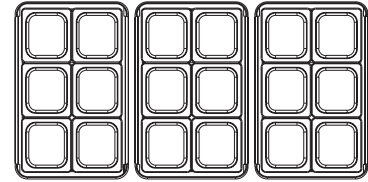

**FULL SIZE PAN CONFIGURATION**

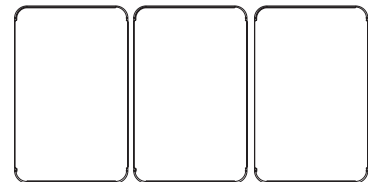

**DRAWER CLEARANCE IS:** 22.88" (58.9cm)  
**DOOR CLEARANCE IS:** 24.5" (62.2cm)

**INSTALLATION NOTE:**  
Refrigeration system is designed so that air will flow under the unit, through the compressor area and out the front of the unit. Any restriction to this air flow path will void the warranties.

**Mechanical Data—Standard Unit**

| MODEL NUMBER | 1/6 SIZE PAN CAPACITY | #OF SHELVES | SHELF AREA. SQ. FT. | STORAGE CAP. CU. FT. | H.P. | VOLTS/HERTZ/ PHASE | AMPS | NEMA PLUG | SHIP WEIGHT     |
|--------------|-----------------------|-------------|---------------------|----------------------|------|--------------------|------|-----------|-----------------|
| 4448N-18M    | 18                    | 2           | 4.53                | 10.7                 | 1/5  | 115/60/1           | 6.5  | 5-15P     | 360 lbs/ 163 kg |
| D4448N-18M   | 18                    | —           | —                   | 1.5                  | 1/5  | 115/60/1           | 6.5  | 5-15P     | 395 lbs/ 179 kg |