



Ultra System Hot Water Dispenser

MODEL UW/UWL

FEATURES

- Provides up to 10.8 gallons per hour of warm water for washing hands or general clean up.
- Plus unlimited cold water for general use.
- Convenient drain, thermally fused to prevent tank damage from dry start-up or loss of water.
- Tank is always open to atmospheric pressure and requires no relief valves.
- 1-year full warranty on parts and labor.

APPLICATIONS

- Bar stations
- Food carts (low wattage model UWL)
- Restrooms
- Office building breakrooms
- Recreational facilities
- Hospital lounges/breakrooms
- Nursing homes
- Remodeling additions
- School cafeterias



SPECIFICATIONS

Model	<input type="checkbox"/> UW	<input type="checkbox"/> UWL	Input Water Temp
AMPS	11.1	6.5	60°F 50PSI
WATTS	1300	750	(15.7°C @3.52
VOLTAGE	115V AC/DC	115V AC/DC	kg/sq cm)
WEIGHT	10 lbs (4.54kg)	10 lbs (4.54kg)	
TANK SIZE	1/2 gal. (1.9L)	1/2 gal. (1.9L)	
VOLUME	10.8	6.25	

Minimal maintenance and counter space needed.

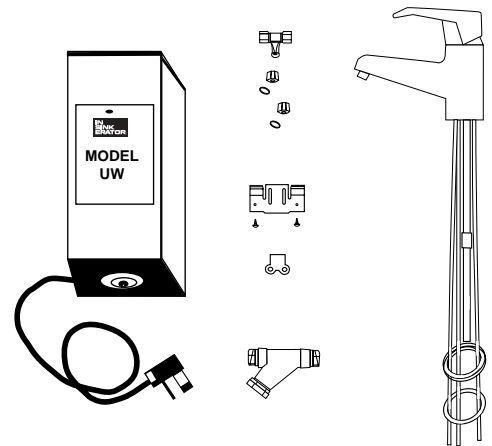
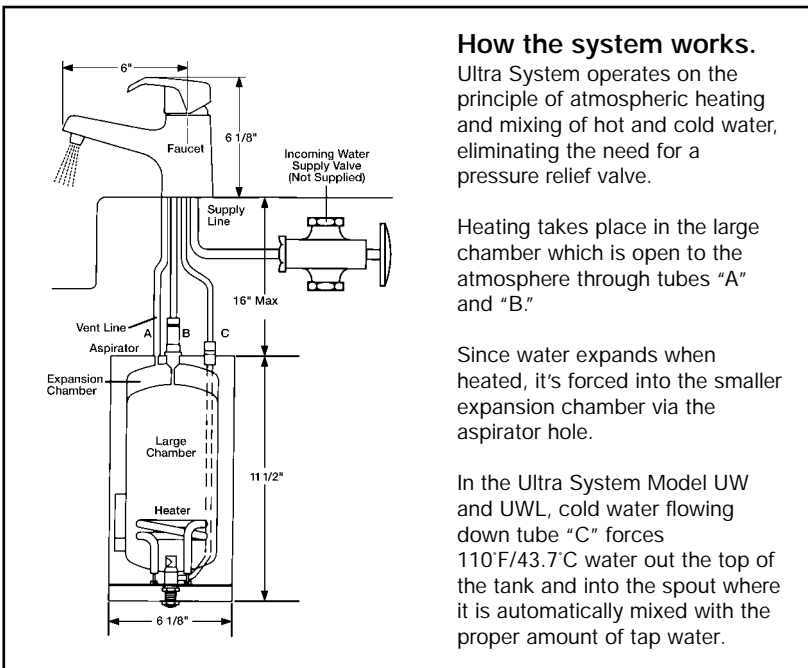

SAMPLE SPECIFICATIONS

Hot Water Dispenser(s) shall be In-Sink-Erator Model UW 1/2-gallon capacity insulated tank with drain plug, 1300 watt heater, or UWL 1/2-gallon capacity insulated tank with drain plug, 750 watt heater. 1-year full warranty on parts and labor.*

*Complete In-Sink-Erator and all parts covered is included in the Care and Use Booklet, packed with each unit.



ULTRA SYSTEM DISPENSER

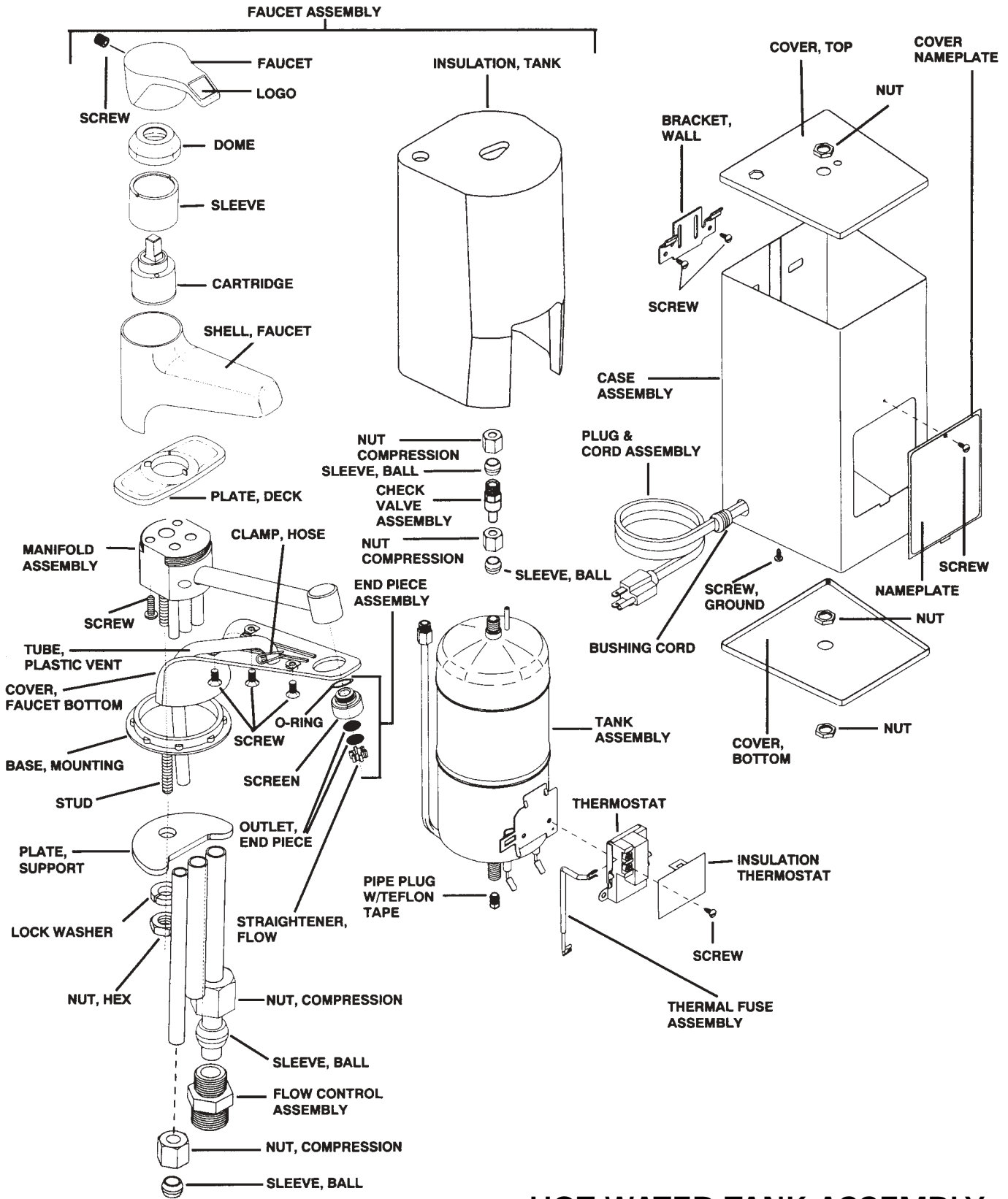

HOT WATER TANK ASSEMBLY