

Twin Infusion Coffee Brewer



Features

Infusion Coffee Brewer

- Brews up to 18.9 gallons (71.5 litres) of perfect coffee per hour.
- Large 5.6-gallon (21.2 litre) tank provides back-to-back brewing capacity at 208-240V applications.
- Two voltages available, 120-208/28amp or 120-240/25amp.
- Each side has 3 brew buttons, allowing for 3 separate brewing profiles. Two programmable batch switches allow full and half batch brewing.
- Brews into 2.5 to 3.8 litre (84 to 128 oz.) airpots and 3.8 and 5.7 litre (1 to 1.5 gal) baseless ThermoFresh™ servers for easy transport of coffee to other locations.
- BrewWISE® intelligence with pre-infusion and pulse brew for maximum flavor extraction. DBC grinder communicates with brewer through Smart Funnel®.
- Energy-saver mode reduces tank temperature during idle periods.
- Digital display in English/Spanish for easier programming and control. Advertising messages and machine status also displayed. Display capable of showing English or Metric measurements.
- Black and stainless models available.
- Compatible with BUNNlink™.

Model ICB-Twin with 1.5 Gal Baseless ThermoFresh® Server in Stainless and Black

(TF server sold separately)

Dimensions: 26.2"H x 20"W x 22.42"D
(66.5cm H x 50.8cm W x 56.9cm D)

For current specification sheets and other information, go to www.bunn.com.

Related Products

Easy Clear® EQHP-10
Product No. : 39000.0004



Easy Clear® EQHP-10L
Product No. : 39000.0001

Single/Dual Filter Pack
Product No. : 20138.0000
Packed per case: 500
Dimensions:

5¼" Base x 4¼" Sidewall
13.3 cm Base x 10.8 cm Sidewall



3.8 litre Lever-Action Airpot
Product No. : 36725.0000 (1 pack)
Product No. : 36725.0100 (6 pack)
Capacity: 128 oz. (3.8 L)

3.0 litre Lever-Action Airpot
Product No.: 32130.0000 (1 pack)
Product No.: 32130.0100 (6 pack)
Capacity: 102 oz. (3.0 L)

2.5 litre Lever-Action Airpot
Product No.: 32125.0000 (1 pack)
Product No.: 32125.0100 (6 pack)
Capacity: 84 oz. (2.5 L)

Universal Airpot Racks
see spec sheet A3.10



3.8 litre (1 gal) ThermoFresh Server
Product No.: 36720.0004 (SST without base)
Product No.: 36720.0005 (BLK without base)

5.7 litre (1.5 gal) ThermoFresh Server
Product No.: 34850.0004 (SST without base)
Product No.: 34850.0005 (BLK without base)



TF Server Stand
Product No.: 38025.0000

Model

ICB-Twin

Agency Listing



Dimensions & Specifications

Model	Product #	Volts	Amps	Tank Heater Watts	Total Watts	Capacity	Cubic Measure	Shipping Weight	Cord Attached
ICB-Twin	37600.0000	120/240	25	6000	6050	18.9 gal/hr	12.06 ft ³	77 lbs	Yes
ICB-Twin	37600.0002	120/208	28	6000	6050	18.9 gal/hr	12.06 ft ³	77 lbs	Yes
ICB-Twin Black	37600.0004	120/240	25	6000	6050	18.9 gal/hr	12.06 ft ³	77 lbs	Yes

Brewing Capacity: Based upon incoming water temperature or 60°F/15.5°C (140°F/60°C) rise.

Electrical: Requires 3-wires plus ground service rated 120/208V or 120/240V, single phase 60Hz.

Plumbing: 20-90 psi (138-621 kPa). Supplied with $\frac{3}{8}$ " male flare fitting.

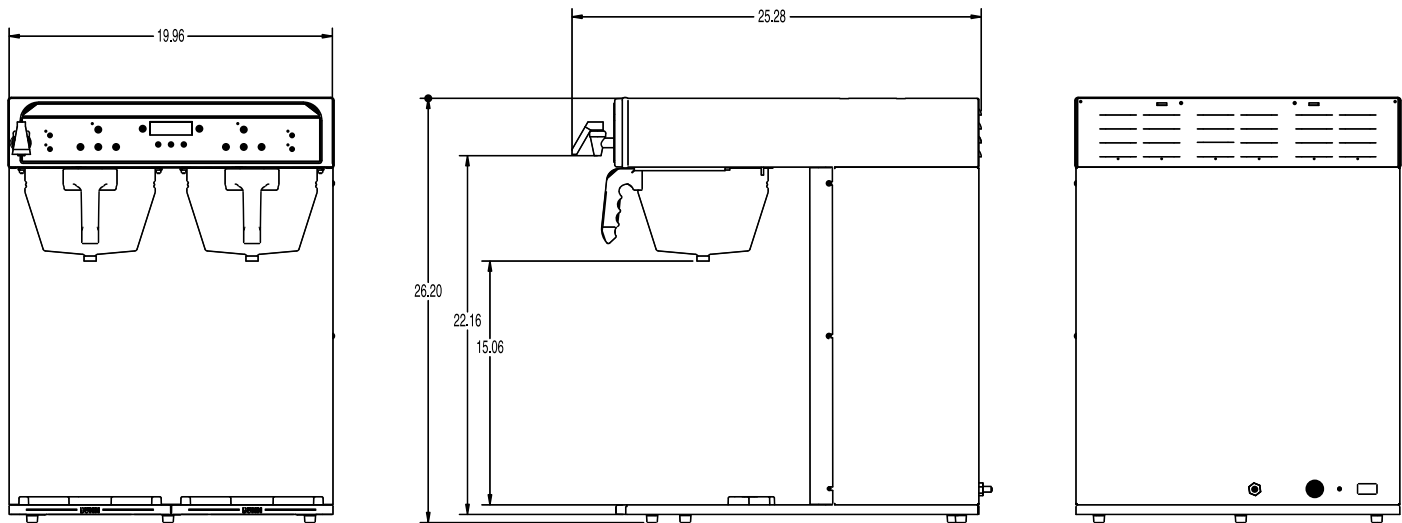

Bunn-O-Matic® Corporation - 1400 Stevenson Drive Springfield, Illinois 62703 • 800-637-8606 • 217-529-6601 • Fax 217-529-6644 • www.bunn.com

BUNN® practices continuous product research and improvement. We reserve the right to change specifications and product design without notice. Such revisions do not entitle the buyer to corresponding changes, improvements, additions or replacements for previously purchased equipment.

All dimensions shown in inches. Bunn-O-Matic Corporation owns all copyrights relating to materials in this publication. Please contact BUNN to request permission to reproduce any portion of this publication.