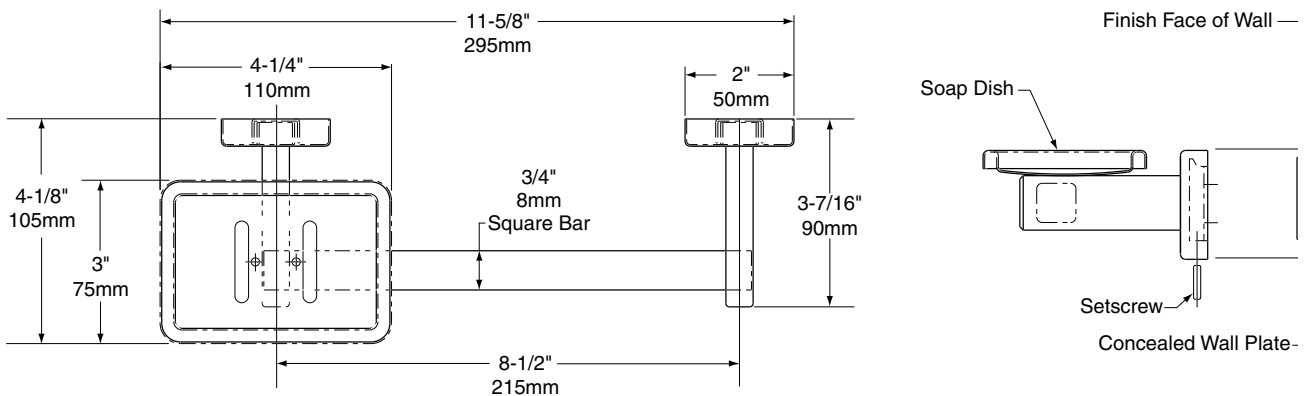

BOBRICK**Technical Data****SURFACE-MOUNTED
SOAP DISH AND BAR****B-7681****MATERIALS:**

Flanges & Support Arms (2) — 18-8 S, type-304, 20-gauge (0.9mm) stainless steel. Each flange has a concealed, 19-gauge (1.0mm) stainless steel mounting bracket. All-welded construction. Secured to wall plates with stainless steel setscrews.

Concealed Wall Plates (2) — 18-8 S, type-304, 19-gauge (1.0mm) stainless steel.

Bar — 18-8 S, type-304, heavy-gauge stainless steel. 3/4" (19mm) square tubing.

Soap Dish — 18-8 S, type-304, 22-gauge (0.8mm) stainless steel. Drawn, one-piece, seamless construction. Welded to the support arm. Two drain holes and two ridges to support bar of soap.

INSTALLATION:

To remove concealed wall plate from back of flanges and mounting brackets, loosen setscrews. Mount each wall plate so prongs are at top; secure with sheet-metal screws, furnished by manufacturer, at points indicated by an S. Engage mounting brackets onto prongs of wall plates, then secure into position by tightening setscrews at bottom of flanges.

Note: Centerline-to-centerline of concealed wall plates must be within 1/16" (1.6mm) of dimension shown.

For plaster or dry wall construction, provide concealed backing to comply with local building codes, then secure unit with screws furnished. For other wall surfaces, provide fiber plugs or expansion shields for use with screws furnished, or provide 1/8" (3mm) toggle bolts or expansion bolts.

SPECIFICATION:

Surface-mounted soap dish and bar shall be type-304 stainless steel with bright polished finish. Flanges and support arms shall be 20 gauge (0.9mm) and equipped with concealed, 19-gauge (1.0mm) mounting brackets that are secured to concealed, 16-gauge (1.6mm) wall plates with stainless steel setscrews. Drawn, one-piece, seamless, 22-gauge (0.8mm) soap dish shall be welded to the support arm and shall have two drain holes and two soap-support ridges. Bar shall be 3/4" (19mm) square tubing. Manufacturer's service and parts manual shall be provided to the building owner/manager upon request.

Surface-Mounted Soap Dish And Bar shall be Model B-7681 of Bobrick Washroom Equipment, Inc., Clifton Park, New York; Jackson, Tennessee; Los Angeles, California; Bobrick Washroom Equipment Company, Scarborough, Ontario; Bobrick Washroom Equipment Pty. Ltd., Australia; and Bobrick Washroom Equipment Limited, United Kingdom.