

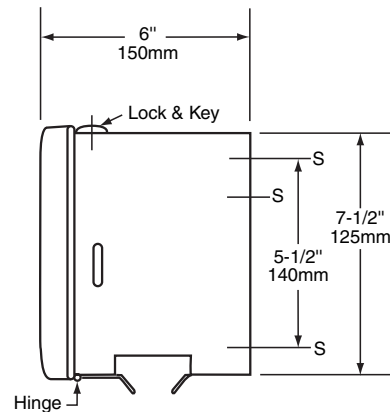

**Technical Data**

# SURFACE-MOUNTED PAPER TOWEL DISPENSER

# B-263

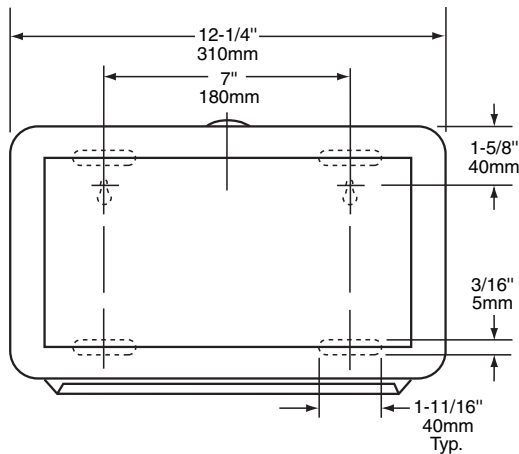

### MATERIALS:

**Cabinet** — 18-8 S, type-304, 22-gauge (0.8mm) stainless steel with satin finish. Welded construction. Equipped with a tumbler lock keyed like other Bobrick washroom accessories.

**Door** — 18-8 S, type-304, 22-gauge (0.8mm) stainless steel with satin finish. Secured to cabinet with a full-length stainless steel piano-hinge.

### OPERATION:

Dispenses singlefold paper towels. Slot in sides of cabinet indicate refill time. Capacity: 400 singlefold paper towels.

### INSTALLATION:

Mount unit on wall with #8 x 1-1/4" (4.2 x 32mm) sheet-metal screws, (not furnished) at points indicated by an S. For plaster or dry wall construction, provide concealed backing to comply with local building codes and secure with sheet-metal screws. For other wall surfaces, provide fiber plugs or expansion shields for use with sheet-metal screws or provide 1/8" (3mm) toggle bolts or expansion bolts.

### SPECIFICATION:

Surface-mounted paper towel dispenser shall be type-304 stainless steel with satin finish. Door shall be secured to cabinet with a full-length stainless steel piano-hinge. Cabinet shall be equipped with a tumbler lock keyed like other Bobrick washroom accessories. Unit shall accommodate 400 singlefold paper towels. Manufacturer's service and parts manual shall be provided to the building owner/manager upon completion of project.

**Surface-Mounted Paper Towel Dispenser shall be Model B-263 of Bobrick Washroom Equipment, Inc., Clifton Park, New York; Jackson, Tennessee; Los Angeles, California; Bobrick Washroom Equipment Company, Scarborough, Ontario; Bobrick Washroom Equipment Pty. Ltd., Australia; and Bobrick Washroom Equipment Limited, United Kingdom.**