



DSF015 - DSF022 - DSF030

Semi Automatic Dough Divider/Rounder

Doyon is your best choice for a superior quality divider/rounder that frees you from the task of dividing and rounding your dough by hand while making it faster, easier and simpler. Better yet, you will be assured of uniformity in dough weight and shape everytime. Doyon divider/rounders are ideal for pies, rolls, tortillas, pizzas, breads and much more...

DSF

“Superior **quality** product
 at an **affordable** price !”

Semi Automatic Dough Divider/Rounder

FEATURING DSF Series

- Models 15, 22 or 30 pieces
- 3 sanitary rounding plates included
- Perfectly scales and rounds pieces
- No oil in or above product zone
- Cutting knives are stainless steel for sanitary purposes
- Easy snap on and off head cover for easy cleaning
- Head can be tilted to the left side for easy cleaning
- Rounding mechanism runs in grease bath for smooth, quiet and long lasting operation
- Manual motor start with built-in thermal overload protection
- Wheel mounted for easy mobility
- On/Off switch for motor on left side base panel
- Hourly production of up to 3 500 pieces (depending on operator and workflow)
- Virtually maintenance free and extremely durable
- Weight range depending on dough consistency
- ETL & ETL Sanitation listed
- One year parts and labor limited warranty

OVERALL DIMENSIONS

23" W X 20" D X 54" H
(584mm X 508 mm X 1370 mm)

ELECTRICAL SYSTEM

120V - 1PH - 8A - 60 Hz NEMA 5-15P
208-240V - 1PH - 4A - 60 Hz NEMA 6-15P
220V - 1PH - 4A - 50 Hz

CAPACITY

DSF015 15 portions
DSF022 22 portions
DSF030 30 portions

WEIGHT BY PORTION (depending on dough consistency)

Model	Min	Max
DSF015	3.5 oz (100 g)	7 oz (200 g)
DSF022	1.4 oz (40 g)	4.8 oz (135 g)
DSF030	0.7 oz (20 g)	3.5 oz (100 g)

SHIPPING

800 lbs (363 kg) approximately

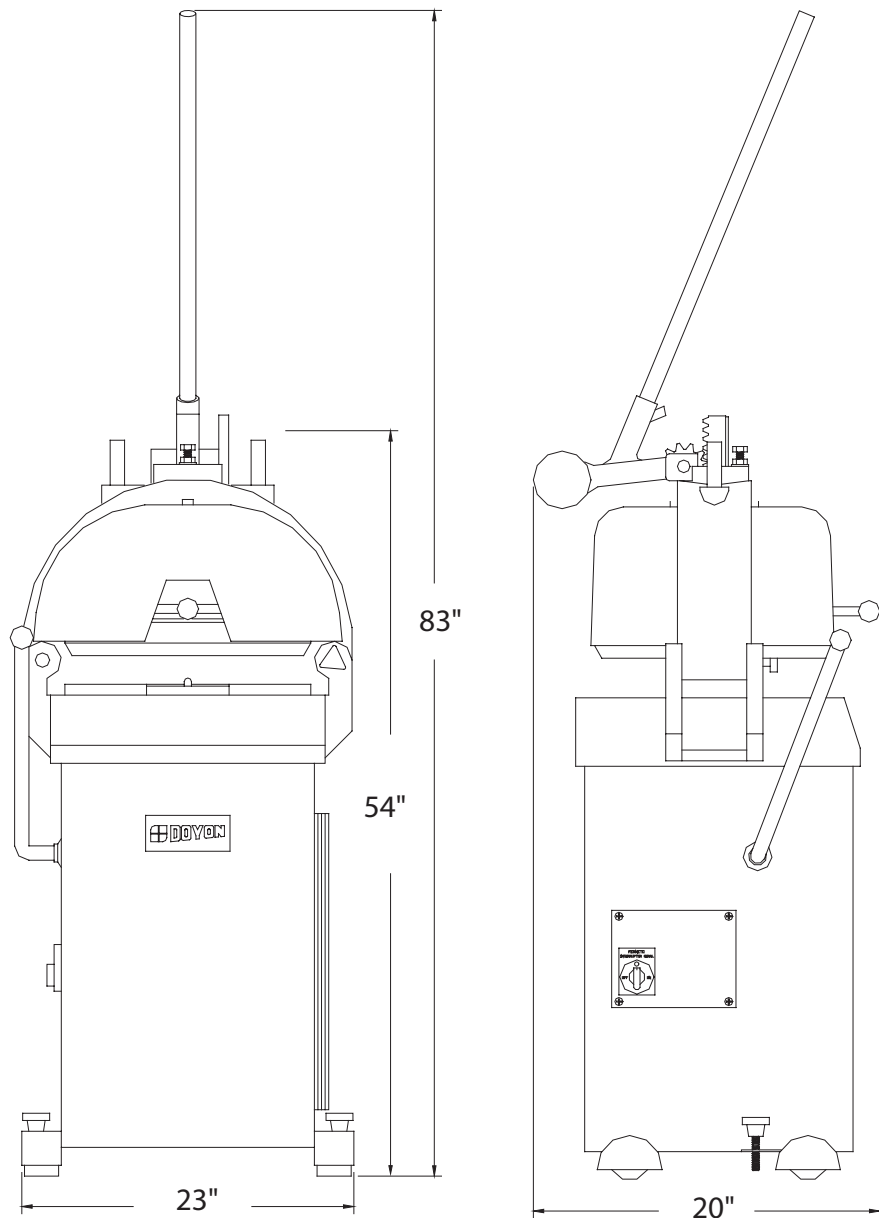

1255, rue Principale
Linière, Beauce, Québec, Canada G0M 1J0

Telephone.: 418-685-3431
Canada: 1-800-463-1636
E-mail : doyon@doyon.qc.ca

Fax: 418-685-3948
U.S.: 1-800-463-4273
Internet : <http://www.doyon.qc.ca>



Your local distributor:

