



DP7 & DP7D
7 pans



DP18
18 pans



DP18AD
18 pans

DP7 & DP18 Series Mobile proofers

“Superior *quality* product
at an *affordable* price !”

Mobile Proofers

FEATURING DP7 & DP18 Series

- Body construction of .063 aluminum, one piece extended base and solid extruded aluminum frame
- Removable stainless steel bottom power assembly for easy cleaning and maintenance
- Powerful, efficient even airflow heating system maintains the right combination of heat and humidity to proof properly
- Easy to read thermostat and humidity control
- Proofs from 90° F to 110° F (32° C to 43° C) with relative humidity up to 95 %
- Water catch pan: keeps area dry, safer
- Heavy duty 3” (7.6 cm) non-marking swivel casters (2 with brakes)
- Reinforced brushed aluminum doors (DP7AD & DP18AD) or thermos glass doors with heavy duty pull handles; standard with right hand hinges, left hand hinges upon request
- All construction is riveted and welded
- ETL approved
- One year parts and labor limited warranty

OPTIONAL

- Perimeter bumpers
- Push handle
- Corner bumpers
- 208V or 240V service

Mobile Proofers from Doyon

Doyon proofers provide uniform proofing from top to bottom with their unique even flow system. These units have been designed for small and medium production of bakery products. They come with solid state heat and humidity controls. It's the easiest way to proof!

Versatility: Croissants, bagels, pastries, breads, rolls and much more.

OVERALL DIMENSIONS

DP7 & DP7AD	22 3/4" W X 29" D X 35 1/2" H (57.8 cm) (73.7 cm) (90.2 cm)
DP7D	27 3/4" W X 29" D X 35 1/2" H (70.5 cm) (73.7cm) (90.2 cm)
DP18 & DP18AD	22 3/4" W X 29" D X 69" H (57.8 cm) (73.7 cm) (175.3 cm)
DP18D	27 3/4" W X 29" D X 69" H (70.5 cm) (73.7cm) (175.3 cm)

INTERIOR DIMENSIONS

DP7 & DP7AD	18 1/2" W X 28 3/4" D X 21 1/4" H (47 cm) (73 cm) (54 cm)
DP7D	23 1/2" W X 28 3/4" D X 21 1/4" H (59.7 cm) (73cm) (54 cm)
DP18 & DP18AD	18 1/2" W X 28 3/4" D X 52 1/4" H (47 cm) (73 cm) (132.7 cm)
DP18D	23 1/2" W X 28 3/4" D X 52 1/4" H (59.7 cm) (73cm) (132.7 cm)

Shelf spacing 3 " (7.6 cm)

ELECTRICAL SYSTEM

120V- 12A - NEMA 5-15P

CAPACITY

DP7 & DP7AD	7 standard sheet pans 18" X 26" (45.8 cm X 66 cm)
DP7D	7 donut screens 23" X 23" (58.4 cm X 58.4cm)
DP18 & DP18AD	18 standard sheet pans 18" X 26" (45.8 cm X 66 cm)
DP18D	18 donut screens 23" X 23" (58.4 cm X 58.4cm)

FINISH

Aluminum

SHIPPING INFORMATION

DP7	150 lbs (68 kg)
DP7D	175 lbs (79 kg)
DP7AD	175 lbs (79 kg)
DP18	250 lbs (114 kg)
DP18D	275 lbs (125 kg)
DP18AD	275 lbs (125 kg)

Electrical service connection located at the back of the unit.

Specifications and design subject to change without notice.

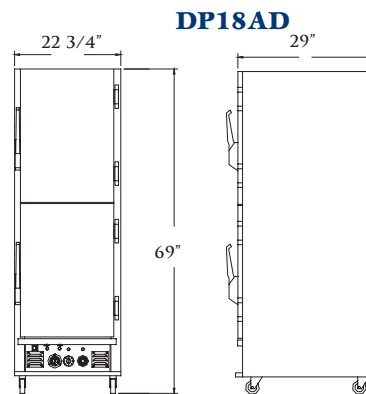
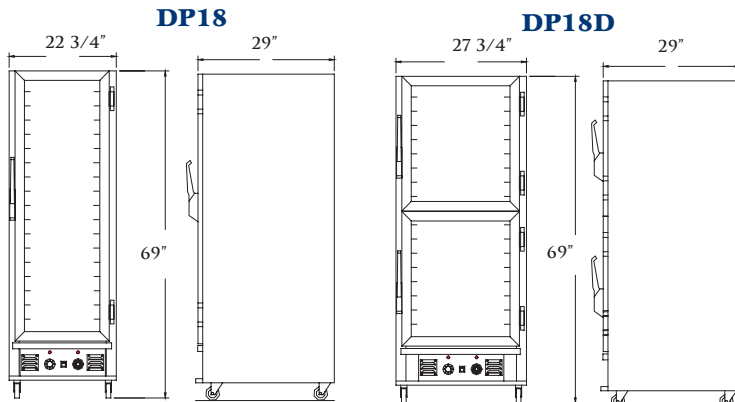
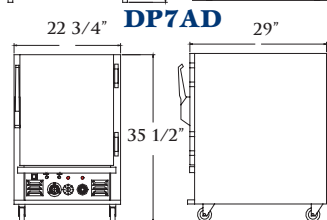
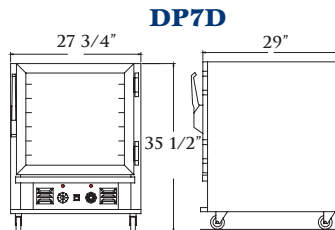
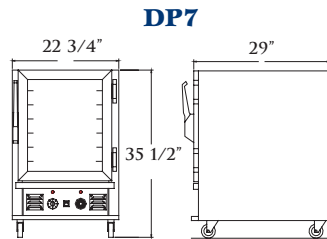

1255, rue Principale
Linière, Beauce, Québec, Canada G0M 1J0

Telephone.: 418-685-3431
Canada: 1-800-463-1636
E-mail : doyon@doyon.qc.ca

Fax: 418-685-3948
U.S.: 1-800-463-4273
Internet : http://www.doyon.qc.ca

Your local distributor:

