



STAINLESS STEEL  
**WALL SHELF WITH  
 CHECK MINDER**



**Item #:** \_\_\_\_\_ **Qty #:** \_\_\_\_\_  
**Model #:** \_\_\_\_\_  
**Project #:** \_\_\_\_\_

For Check Minder Provision  
 on any shelf use **TA-77**.



Model	Length	Wt.
WS-12-36CM	12" x 36"	15 lbs.
WS-12-48CM	12" x 48"	19 lbs.
WS-12-60CM	12" x 60"	21 lbs.
WS-12-72CM	12" x 72"	25 lbs.
WS-12-96CM	12" x 96"	32 lbs.

**FEATURES:**

Furnished with a 1-1/2" sanitary rolled rim with a 1-1/4" turn-up at rear. Ends are turned down square. Brackets can be positioned to accommodate wall studs. 96" unit furnished with 3 brackets.

**Check Minder** holds checks with ease. Floating ball mechanism quickly grabs checks and holds them in place.

**CONSTRUCTION:**

All TIG welded.  
 Exposed surfaces polished to a satin finish.

**MATERIAL:**

18 gauge type "430" stainless steel.

**DETAILS and SPECIFICATIONS**

TOL ± .500"

ALL DIMENSIONS ARE TYPICAL

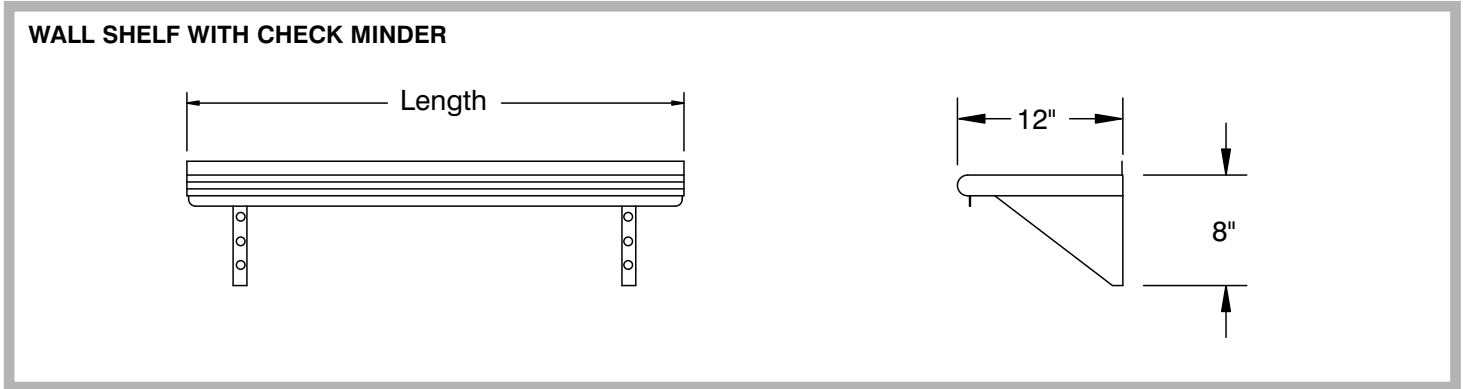

**ALUMINUM  
 CHECK MINDER**



**FEATURES:**

**Check Minder** holds checks with ease. Floating ball mechanism quickly grabs checks and holds them in place. Mounts to existing wall or shelf.

**MATERIAL:**

Extruded Anodized aluminum.

Model	Length	Wt.
CM-24	24"	1.5 lbs.
CM-36	36"	2.25 lbs.
CM-48	48"	3 lbs.



**NEW YORK**  
 (800) 645-3166  
 Fax: (631) 242-6900

**GEORGIA**  
 (800) 832-1218  
 Fax: (770) 775-5625

**TEXAS**  
 (800) 527-0353  
 Fax: (972) 932-4795

**NEVADA**  
 (800) 446-8684  
 Fax: (775) 972-1578