



STAINLESS STEEL EQUIPMENT FILLER TABLE

FEATURES:

TOP is furnished with 1 5/8" sanitary rolled rim edge in front. Square edges on sides and 1/1/2" splash of single metal thickness on rear.

Hat channels stud welded to top which reinforces and maintains a level working surface.

Welded Front to Back Leg Assembly.

Rear (Left to Right) Stretcher bolts to side leg assemblies.

CONSTRUCTION:

All TIG welded. Exposed weld areas polished to match adjacent surfaces.

Entire top mechanically polished to a satin finish.

Top is sound deadened.

Roll formed embossed galvanized hat channels are secured to top by means of structural adhesive and weld studs.

Gussets welded to support hat sections.

MATERIAL:

TOP: 16 gauge stainless steel type "304" series.

STRETCHERS: 1 5/8" diameter tubular stainless steel.

LEGS: 1 5/8" diameter tubular stainless steel.

Stainless steel gussets.

1" stainless steel bullet feet.

Item #: _____ **Qty #:** _____

Model #: _____

Project #: _____



Model #	Width	Length	Wt.
TFMS-182	18"	24"	27 lbs.
TFMS-180	18"	30"	35 lbs.
TFMS-183	18"	36"	43 lbs.
TFMS-152	15"	24"	25 lbs.
TFMS-150	15"	30"	33 lbs.
TFMS-153	15"	36"	41 lbs.
TFMS-122	12"	24"	22 lbs.
TFMS-120	12"	30"	31 lbs.
TFMS-123	12"	36"	39 lbs.

DETAILS and SPECIFICATIONS

TOL ± .500"

ALL DIMENSIONS ARE TYPICAL

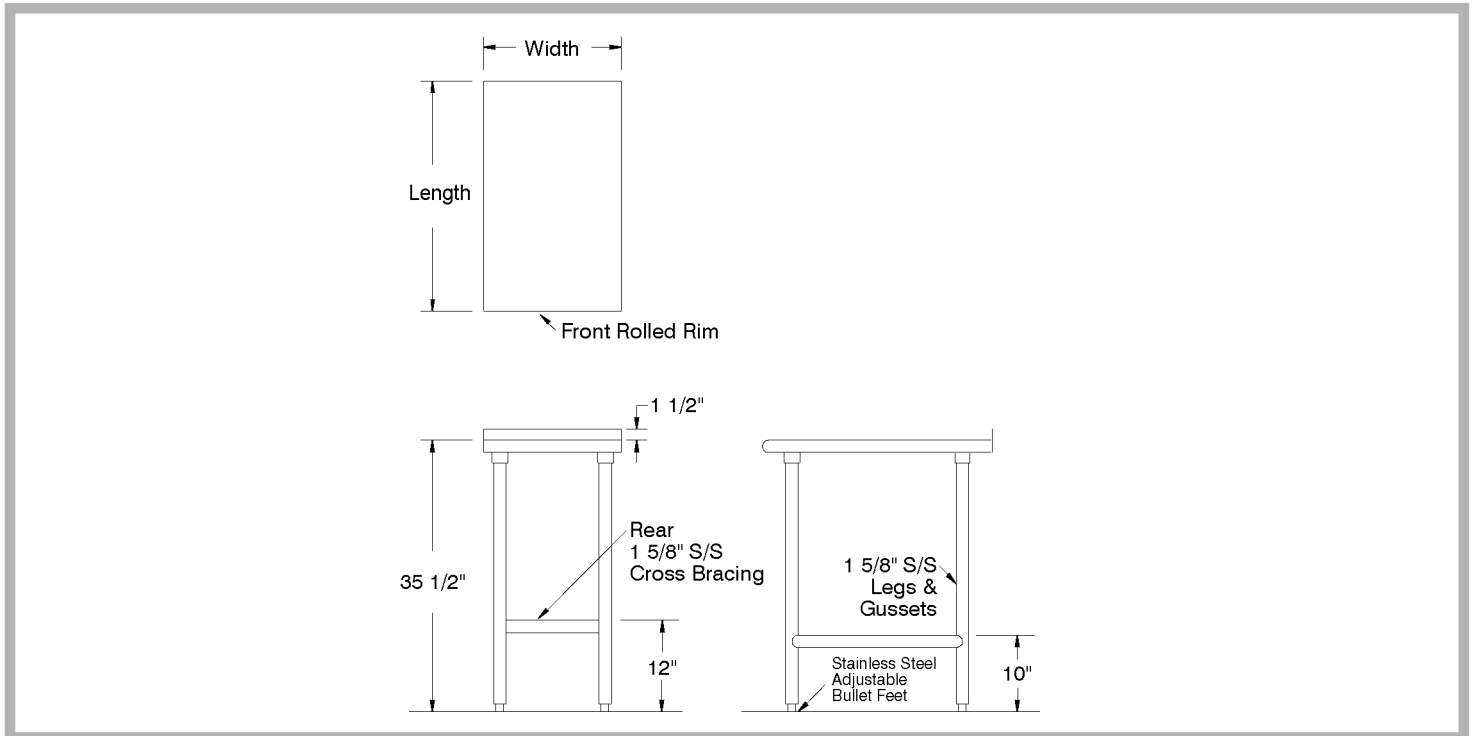

NEW YORK
(800) 645-3166
Fax: (631) 242-6900

GEORGIA
(800) 832-1218
Fax: (770) 775-5625

TEXAS
(800) 527-0353
Fax: (972) 932-4795

NEVADA
(800) 446-8684
Fax: (775) 972-1578