

# SMART TABLE MODIFICATIONS

## SIZE MODIFICATIONS

- \_\_\_ **TA-33** Special Working Height
- \_\_\_ **TA-59** 36" Wide Equipment Stand
- \_\_\_ **TA-6** Extra Length for Standard Tables over 12'  
(Tables Over 14' Require Field Joint TA-57)
- \_\_\_ **TA-61** Special Modification Charge (1 Charge Per Table)
- \_\_\_ **TA-65** Enclosed Base Units Over 12' (Open Base Table)
- \_\_\_ **TA-66** Enclosed Base Units Over 12' (Sliding Door Units)
- \_\_\_ **TA-67** Enclosed Base Units Over 12' Hinged Door Units)
- \_\_\_ **TA-78** Additional Lin. Ft. Past 12' For Table Mt. Shelf  
(For ODS, OTS, TS & DS Shelving only)
- \_\_\_ **TA-79** Flour Trough (Factory installation only)
- \_\_\_ **TA-105** Modify Enclosed Base Table with Drawers to 24" W
- \_\_\_ **TA-110** Modify Enclosed Base Table with Drawers to 36" W

## TOP MODIFICATIONS

- \_\_\_ **TA-1** Notch Backsplash For Roll Up Door with Pass-Thru
- \_\_\_ **TA-3** Stainless Steel Hat Channel & Gusset Upgrade
- \_\_\_ **TA-7** 10" Rear Splash
- \_\_\_ **TA-8** Column Notch in Rear Splash (Includes Splash)
- \_\_\_ **TA-10** 5" Partial Back Splash
- \_\_\_ **TA-12** Countertop Edge
- \_\_\_ **TA-22** Square Edge Table
- \_\_\_ **TA-28** Cut-Out For Cold Well
- \_\_\_ **TA-30** 1-1/2" Side Splash
- \_\_\_ **TA-31** 5" Side Splash
- \_\_\_ **TA-32** 10" Side Splash
- \_\_\_ **TA-34A** Top Cut-Out Up To 36" Length
- \_\_\_ **TA-34B** Top Cut-Out Over 36" Length
- \_\_\_ **TA-35** Splash Cut-Out
- \_\_\_ **TA-56** 5" NSF Partition
- \_\_\_ **TA-56A** 18" NSF Partition
- \_\_\_ **TA-57** Prepare Welded Field Joint (Welded in field by others)
- \_\_\_ **TA-57A** Bolted Field Joint (Bolted in field by others)



**TA-58 Shown**

- \_\_\_ **TA-58** Stepdown to 24" Working Height
- \_\_\_ **TA-62** Duplex Electrical Outlet (Under Flat Top)
- \_\_\_ **TA-62A** Duplex Electrical Outlet (in VKS Rear Splash)

- \_\_\_ **TA-62B** Duplex Electrical Outlet (in KSS Rear Splash. Includes 2" Return)
- \_\_\_ **TA-62C** Duplex Electrical Outlet GFI (Specify Location)
- \_\_\_ **TA-62D** Doghouse Electrical Outlet Box (Includes Duplex Outlet)
- \_\_\_ **TA-64** Urn Trough (Factory installation only)
- \_\_\_ **TA-75** Mitered Edge

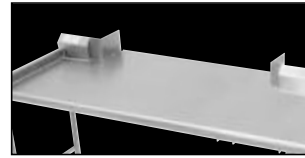

**TA-84 Shown**

- \_\_\_ **TA-82** Scrap Chute (6" dia. opening)
- \_\_\_ **TA-84** Simple Pass-Thru
- \_\_\_ **TA-87** Enclosed Rear Splash
- \_\_\_ **TA-96** Can Opener Provision for S-1 & S-11  
(Customer to provide location)
- \_\_\_ **TA-100** Bull Nose All Sides of Worktable
- \_\_\_ **TA-100A** Bull Nose All Sides of Shelf
- \_\_\_ **TA-101** Rear Tray Lock
- \_\_\_ **TA-106** Mirror HI-LITE Edge
- \_\_\_ **TA-108** 2" Hole with Grommet for Appliance Cord  
(Specify Hole Location)
- \_\_\_ **TA-112** Hubble Outlet
- \_\_\_ **TA-113** Notch Top for Buyout Unit

## BASE MODIFICATIONS

- \_\_\_ **TA-4** Removable Access Panel
- \_\_\_ **TA-5** Curb Mounting Provision
- \_\_\_ **TA-13** Pad Lock Hasp
- \_\_\_ **TA-15** Provision for Built In Drawer Warmer
- \_\_\_ **TA-23** Welded Set-Up Table/Crating
- \_\_\_ **TA-24** Shell Crating
- \_\_\_ **TA-27** Control Panel (Must add TA-34A or TA-34B)
- \_\_\_ **TA-36A** Sliding/Hinge Stainless Steel Doors
- \_\_\_ **TA-36B** Two 1/2 Height Stainless Steel Hinge Doors
- \_\_\_ **TA-37** Stainless Enclosed Base



**TA-39 Shown**

- \_\_\_ **TA-39** 24" Louvered Hinged Doors
- \_\_\_ **TA-40** Remove Undershef in Cabinet Base For Slide in Buyout
- \_\_\_ **TA-42** Interior Partition (2.5"x30")
- \_\_\_ **TA-43** Filler Panel (3"x30" with Flanged Feet)



**NEW YORK**  
(800) 645-3166  
Fax: (631) 242-6900

**GEORGIA**  
(800) 832-1218  
Fax: (770) 775-5625

**TEXAS**  
(800) 527-0353  
Fax: (972) 932-4795

**NEVADA**  
(800) 446-8684  
Fax: (775) 972-1578

# SMART TABLE MODIFICATIONS



**TA-44 Shown**

- \_\_\_ **TA-44** K.D. Aluminum Pan Rack Slides (6 slides. Table min. lgth. 3 ft.)

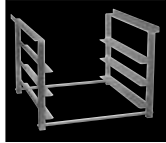

**TA-45 Shown**

- \_\_\_ **TA-45** K.D. Aluminum Glass Rack Slides (3 slides. Table min. lgth. 3 feet)
- \_\_\_ **TA-46** Door Locks
- \_\_\_ **TA-48** 12"x12" Cut-Out in Back Panel or Undersheff for Plumbing
- \_\_\_ **TA-55** Remove Back Panel (on Enclosed Base)
- \_\_\_ **TA-70** S/S Tubular Tray Divider (12" sections)
- \_\_\_ **TA-73** Tubular Tray Slide w/Dropdown (Stationary Tray Slide Available. Factory installation only)
- \_\_\_ **TA-74** Solid Tray Slide
- \_\_\_ **TA-76** Paint on Sound Deadening
- \_\_\_ **TA-91** Poly Retaining Clips **Includes TA-22** (S/S top table)
- \_\_\_ **TA-92** 12" Apron (in front of sink)

## SINK MODIFICATIONS

- \_\_\_ **TA-107** Vacuum Breaker Holes on Tables (Includes Backsplash with 2" Return)

## UNDERSHEFF MODIFICATIONS

- \_\_\_ **TA-9** 1-1/2" Turn-Up for Undersheffs
- \_\_\_ **TA-48** 12"x12" Cut-Out in Back Panel or Undersheff for Plumbing
- \_\_\_ **TA-94** Upgrade 16 Ga. 304 S/S Undersheff
- \_\_\_ **TA-108** 2" Hole with Grommet for Appliance Cord (Specify Hole Location)
- \_\_\_ **TA-366** Reinforced Understructure For Undersheffs

## OVERSHEFF MODIFICATIONS

- \_\_\_ **TA-47** Shelf Mounting Bracket for Existing Table
- \_\_\_ **TA-49** Wall Shelf 2" offset
- \_\_\_ **TA-60** Special Sizing Charge for Shelves
- \_\_\_ **TA-62** Duplex Electrical Outlet (Under Flat Top)
- \_\_\_ **TA-62D** Doghouse Electrical Outlet Box (Includes Duplex Outlet)
- \_\_\_ **TA-71** Heat Lamp Mounting Provision
- \_\_\_ **TA-77** Check Minder Shelf Provision (Factory installation only)
- \_\_\_ **TA-99** 16 Ga. S/S 304 Upgrade for Wall and Over Shelves
- \_\_\_ **TA-102** 24" x 24" Extension for Microwave or Computer Shelf (Add to OTS and ODS Shelves. See page 45)
- \_\_\_ **TA-103** 24" Wide PT Shelf (Mid mount only. PT Series Shelf, see pg. 47. Add to 18" Wide Shelf)
- \_\_\_ **TA-104** Additional Length Over 12' (Add to 18" Shelf) (CU & CDS Shelving Only. Max. Lgth. is 14' as Single Piece)

## LEG MODIFICATIONS

- \_\_\_ **TA-16** Galvanized Leg with Plastic Bullet Foot
- \_\_\_ **TA-19** Flanged Stainless Steel Bullet Feet
- \_\_\_ **TA-20** Stainless Steel Leg with S/S Bullet Foot
- \_\_\_ **TA-21** Stainless Steel Bullet Foot
- \_\_\_ **TA-95** Upgrade 16 Ga. 304 S/S Legs Only

## MODIFIED EB-SS-3012

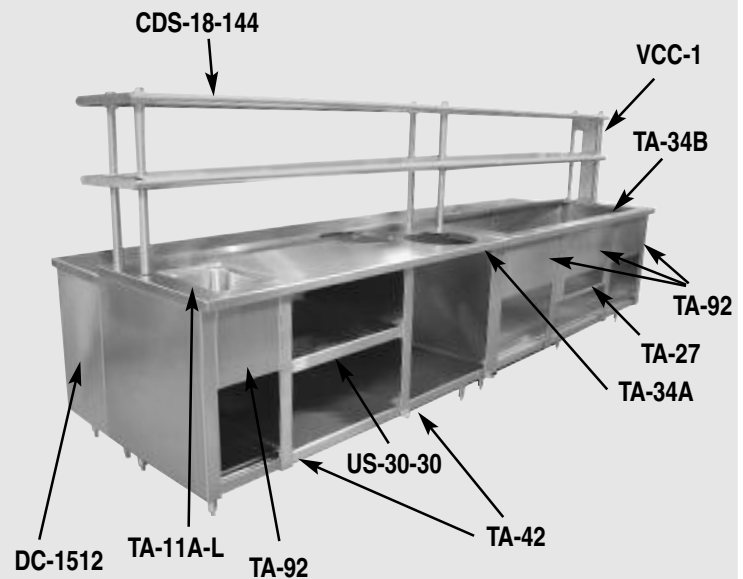

Duplex Electrical Outlets  
TA-62  
TA-62A  
TA-62B  
TA-62C



Doghouse Duplex Electrical Outlet  
TA-62D **NEW!**



TA-77  
Check Minder Shelf Provision

(See Pg. 42 for Full Descriptions)

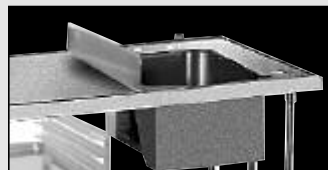

TA-56  
5" NSF Partition  
TA-56A  
18" NSF Partition  
TA-92 \$120 lin. ft.  
12" Apron



TA-75  
Mitered Edge



TA-112  
Hubble Outlet

**TOP ACCESSORIES**



TA-41 Shown

- \_\_\_ TA-29 Rear Splash Capping Strip
- \_\_\_ TA-41 Poly-Vance 5/8" Cutting Board
- \_\_\_ TA-52 Drop-In urn Trough
- \_\_\_ TA-81 Stainless Steel Cutting Surface

**BASE ACCESSORIES**



TA-54 Shown

- \_\_\_ TA-54 Removable Kick Plate
- \_\_\_ TA-63 Removable Shelving (In addition to standard shelf)

**OVERSHELF ACCESSORIES**

- \_\_\_ TA-83 Spice Bins

**POTRACK ACCESSORIES**

- \_\_\_ TA-86 Stainless Steel Pot Hooks
- \_\_\_ TA-89 Double Sided Plated Pot Hooks (Package of 4)
- \_\_\_ TA-89A Single Sided Plated Pot Hooks (Package of 4)
- \_\_\_ TA-98 Stainless Steel Flat Bar in lieu of Chain

**TOP ACCESSORIES**

- \_\_\_ TA-84A Knife Rack for Rolled Rim Tables
- \_\_\_ TA-84B Knife Rack for Poly Top Tables
- \_\_\_ TA-84C Knife Rack for Square Edge Tables

**DRAWER ACCESSORIES**

- \_\_\_ TA-90 Drawer Adapter (Non-catalog tables. Specify table width)
- \_\_\_ TA-93 Wall Clips (for 5" & 10 1/2" splash only)

**LEG ACCESSORIES**

- \_\_\_ TA-72 Leg to Wall Brace (Set per table)

**REAR SPLASH CAPPING STRIP**



*16 Ga. "304" Stainless Steel  
Adhesive Tape Backing*

- \_\_\_ TA-29

**BUMPER GUARDS**



16 ga., 304 Stainless Steel. Bracket Included

- \_\_\_ **BG-48** 2" x 4" x 48"
- \_\_\_ **BG-60** 2" x 4" x 60"

**CORNER GUARDS**



*16 Ga. "304" Stainless Steel  
Adhesive Tape Backing*

- \_\_\_ **CG-48** 2" x 2" x 48"
- \_\_\_ **CG-60** 2" x 2" x 60"

**CHECK MINDER**

**Check Minder** holds checks with ease. Floating ball mechanism quickly grabs checks and holds them in place. Mounts to existing wall or shelf.



Ft.	MODEL	Approx. Wt.
2'	___ <b>CM-24</b>	1.5 lbs.
3'	___ <b>CM-36</b>	2.25 lbs.
4'	___ <b>CM-48</b>	3 lbs.

# SMART TABLE ACCESSORIES

## Casters

(125 lbs. Load Capacity Per Caster)



TA-25

- \_\_\_ TA-25 Set of 4
- \_\_\_ TA-25A Set of 6
- Add price to Above for:**
- \_\_\_ TA-25B Brakes on All Casters
- \_\_\_ TA-25C Upgrade to Caster with Heavy Duty Urethane Wheels

## Heavy Duty Casters for Equipment Stands



TA-255

(1000 lbs. Distributed Weight)

- \_\_\_ TA-255 Super Heavy Duty set of 4
- \_\_\_ TA-256 Super Heavy Duty set of 6

**ALL CASTERS  
SHIP VIA UPS!**



**NEW YORK**  
(800) 645-3166  
Fax: (631) 242-6900

**GEORGIA**  
(800) 832-1218  
Fax: (770) 775-5625

**TEXAS**  
(800) 527-0353  
Fax: (972) 932-4795

**NEVADA**  
(800) 446-8684  
Fax: (775) 972-1578