



ALUMINUM

PAN RACKS

All Welded Curved Top



Front Load



Side Load

Item #: _____ **Qty #:** _____
Model #: _____
Project #: _____

FEATURES:

- Curved top design.
- Heavy duty welded construction with 6 cross supports.
- 1" x 1 1/2" ribbed angles.
- Heavy duty 5" stem bolted swivel casters.
- 500 lb. capacity.

CONSTRUCTION:

- Fully welded 1" square tubing ladder assembly.
- Angles are 1" x 1 1/2" x 20" on front load pan rack and 1" x 1 1/2" x 17 3/4" on side load pan rack.

MATERIAL:

- 6063-T52 extruded aluminum angles, upright tubing, and support pieces.

MODEL #	Description	Pan Capacity	A Shelf Spacing	Overall Size L x W x H	Weight
PR10-3W	Front Load	10 Full Size	3"	20 1/4" x 26" x 38 1/2"	13 lbs.
PR10-6W	Front Load	10 Full Size	6"	20 1/4" x 26" x 69 1/4"	19 lbs.
PR12-5W	Front Load	12 Full Size	5"	20 1/4" x 26" x 69 1/4"	25 lbs.
PR15-4W	Front Load	15 Full Size	4"	20 1/4" x 26" x 69 1/4"	27 lbs.
PR18-3W	Front Load	18 Full Size	3"	20 1/4" x 26" x 63 1/4"	27 lbs.
PR20-3W	Front Load	20 Full or 40 Half Size	3"	20 1/4" x 26" x 69 1/4"	29 lbs.
PR30-2W	Front Load	30 Full Size	2"	20 1/4" x 26" x 69 1/4"	36 lbs.
PR10-6WS	Side Load	10 Full Size	6"	28 1/4" x 18" x 69 1/4"	24 lbs.
PR12-5WS	Side Load	12 Full Size	5"	28 1/4" x 18" x 69 1/4"	27 lbs.
PR15-4WS	Side Load	15 Full Size	4"	28 1/4" x 18" x 69 1/4"	25 lbs.
PR18-3WS	Side Load	18 Full Size	3"	28 1/4" x 18" x 63 1/4"	27 lbs.
PR20-3WS	Side Load	20 Full Size	3"	28 1/4" x 18" x 69 1/4"	27 lbs.



NEW YORK
 (800) 645-3166
 Fax: (631) 242-6900

GEORGIA
 (800) 832-1218
 Fax: (770) 775-5625

TEXAS
 (800) 527-0353
 Fax: (972) 932-4795

NEVADA
 (800) 446-8684
 Fax: (775) 972-1578

DIMENSIONS and SPECIFICATIONS

TOL ± .500"

ALL DIMENSIONS ARE TYPICAL

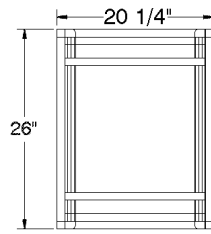

Front Load

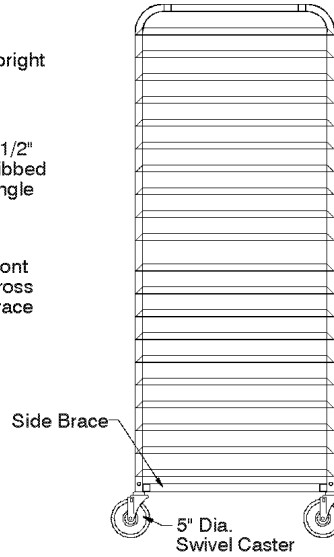
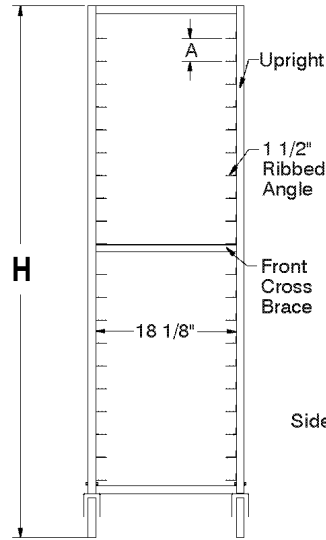

Side Load

