



STAINLESS STEEL
**DISHTABLE
 UNDERCOUNTER**

COMPACT - EFFICIENT - ECONOMICAL



20" x 20" x 5"
Deep Drawn
 Bowl

DTU-U60-48R Shown.
 (Dishwasher by others)

FEATURES:

Tile edge for ease of installation.
 Table is furnished with 10" splash with a 2" return.

CONSTRUCTION:

All TIG welded.
 Welded areas blended to match adjacent surfaces and to a satin finish.
 Gussets welded to a stainless steel support channel.

MECHANICAL:

Faucet holes in SPLASH punched on 8" centers (Faucet not included).
 Waste Drain included.

MATERIAL:

LEGS are Stainless Steel with Welded Cross Bracing.
 TOP with bowl, drainboard, splash and rolled rims are fabricated using 16 gauge stainless steel type "304" series.

Item #: _____ **Qty #:** _____
Model #: _____
Project #: _____

Model #	Length	Wt.
DTU-U60-48L	52"	80 lbs.
DTU-U60-48R	52"	80 lbs.
DTU-U60-72L	72"	115 lbs.
DTU-U60-72R	72"	115 lbs.

Left or Right designation is determined by sink location.

**Optional
 Basket with Welded
 Slide Bar**

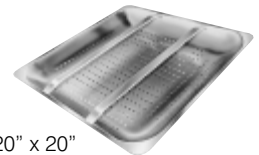

DTA-62

20" x 20"

ACCESSORIES	Model #
Faucet	
Prerinse Basket	

DIMENSIONS and SPECIFICATIONS

TOL ± .500"

ALL DIMENSIONS ARE TYPICAL

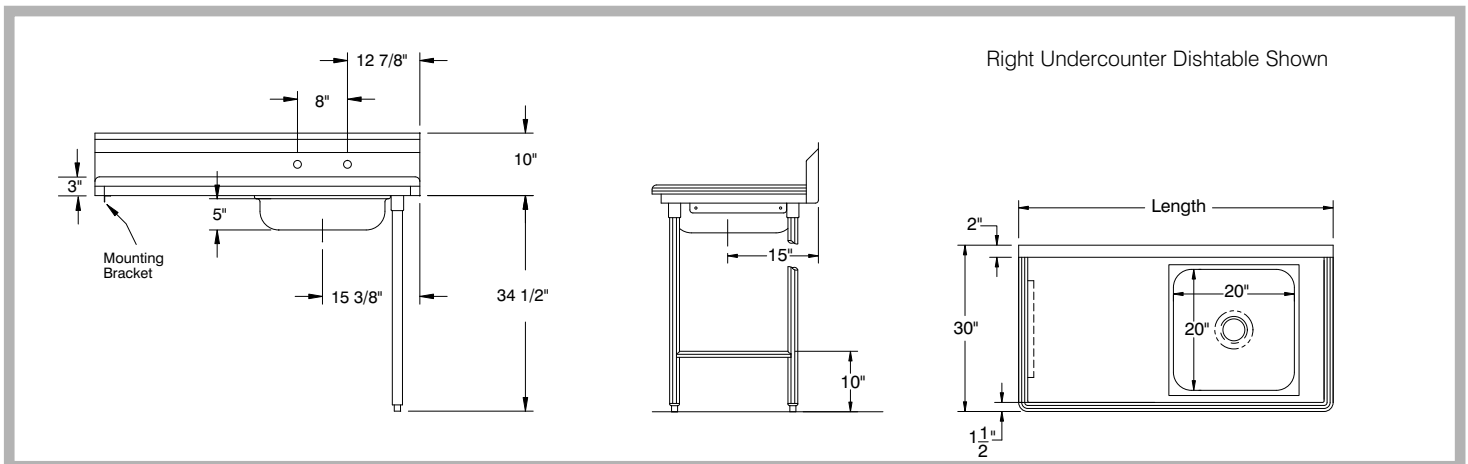

NEW YORK
 (800) 645-3166
 Fax: (631) 242-6900

GEORGIA
 (800) 832-1218
 Fax: (770) 775-5625

TEXAS
 (800) 527-0353
 Fax: (972) 932-4795

NEVADA
 (800) 446-8684
 Fax: (775) 972-1578

For Assistance with
 Smart Modifications & Accessories Call:

1-800-498-6634 Fax: 631-586-2933
 smartfab@advancetabco.com