



STAINLESS STEEL MOBILE MIXER & EQUIPMENT TABLES



MOBILE
MIXER TABLE



MIXER
EQUIPMENT
TABLE

Drawer Optional

Item #: _____ **Qty #:** _____

Model #: _____

Project #: _____

MOBILE MIXER TABLES

Overall Dim.	Model #	Style	Length	Weight
30" x 30"	MT-MS-300	Stainless Steel	30"	85 lbs.
30" x 36"	MT-MS-303	Stainless Steel	36"	95 lbs.
30" x 30"	MT-MG-300	Galvanized	30"	85 lbs.
30" x 36"	MT-MG-303	Galvanized	36"	95 lbs.

MIXER EQUIPMENT TABLES

Overall Dim.	Model #	Style	Length	Weight
24" x 30"	AG-MP-30	Stainless Steel	30"	65 lbs.

MOBILE MIXER TABLES

FEATURES:

TOP is furnished with a 2" x 1" square die embossed NO-DRIP countertop offset edge with a 1/2" return on 4 sides.

Cross Bracing welded to front legs. Cross Bracing on sides is bolted to legs and requires assembly.

Pan Rack Slides sized for (6) 18" x 26" pans.

MATERIAL:

MT-MS SERIES - Stainless Steel Base

TOP is 14 gauge stainless steel type "304" series with galvanized understructure.

LEGS are 1 5/8" diameter, stainless steel. Gussets are stainless steel. (4) 5" swivel casters with rubber wheels. (2) with brakes

PAN RACK is aluminum with 2" tray slide spacing.

MT-MG SERIES - Galvanized Base

TOP is 14 gauge stainless steel type "304" series with galvanized understructure.

LEGS are 1 5/8" diameter, galvanized steel. Gussets are galvanized steel.

(4) 5" swivel casters with rubber tires. (2) with brakes.

PAN RACK is aluminum with 2" tray slide spacing.

MOBILE EQUIPMENT TABLES

FEATURES:

TOP is furnished with a 2" x 1" square die embossed NO-DRIP countertop offset edge with a 1/2" return on 4 sides.

Aluminum die cast "leg to shelf" clamp secures shelf to leg eliminating unsightly nuts and bolts. Undershelf is adjustable.

Pre-engineered angle adapters insure ease of future drawer installation (Mixer Equipment Table Only).

Stainless steel handle and two rubber bumpers secured to table top.

MATERIAL:

AG-MP-30

TOP is heavy gauge stainless steel type "430" series with galvanized understructure.

UNDERSHELF is galvanized steel.

LEGS are 1 5/8" dia. tubular galvanized steel with galvanized steel gussets and (2) 1" adjustable plastic bullet feet.

(2) 5" swivel casters with brakes supplied.

CONSTRUCTION:

Roll formed embossed galvanized hat channels are secured to top by means of structural adhesive and weld studs.

Gussets welded to support hat sections.

All TIG welded. Exposed weld areas finished to match adjacent surfaces.

Entire Top is mechanically polished to a satin finish and is sound deadened.



NEW YORK
(800) 645-3166
Fax: (631) 242-6900

GEORGIA
(800) 832-1218
Fax: (770) 775-5625

TEXAS
(800) 527-0353
Fax: (972) 932-4795

NEVADA
(800) 446-8684
Fax: (775) 972-1578

DETAILS and SPECIFICATIONS

TOL ± .500"

ALL DIMENSIONS ARE TYPICAL

MOBILE MIXER TABLE

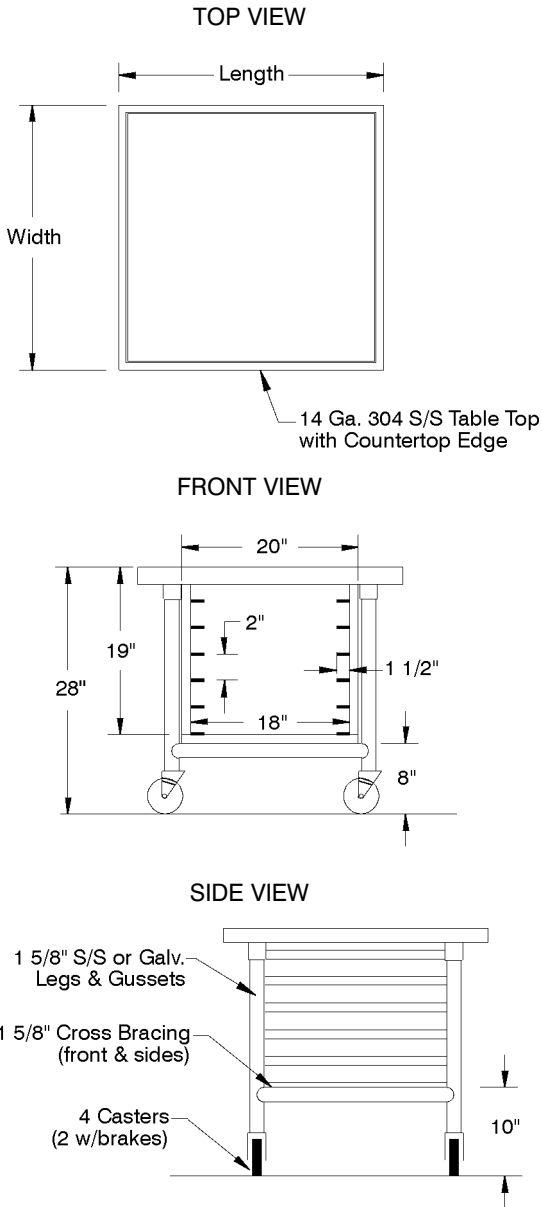

MOBILE EQUIPMENT TABLE

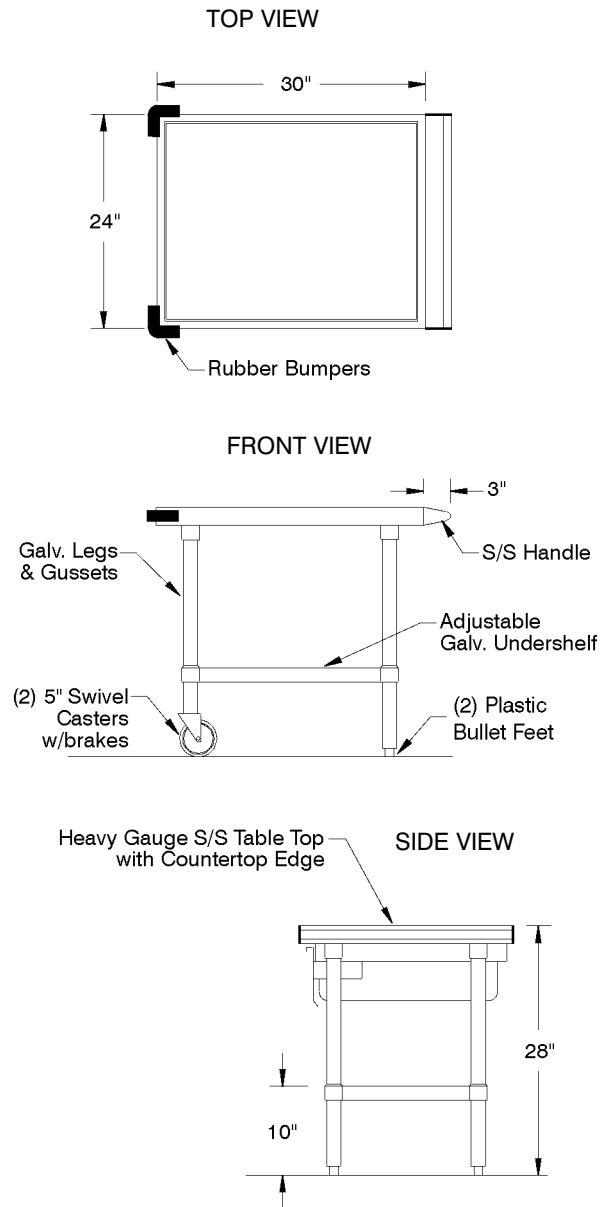

Countertop Edge Detail

