



Job No. _____

Item No. _____

Quantity _____

SR14E Super Runner Electric Fryer



Shown with optional casters

Designed Specifically for the Commercial Economy Electric Market

Maximize your profits - combine efficiency and capacity in this all-purpose, economy fryer with a 13.7" x 13.7" (35 x 35 cm) frying area, and oil capacity of 35-40 lbs.(20-23 liters).

Fry a wide variety of products with Dean's electric SR14E fryer; from appetizers to specialty foods -- chicken, fries, and breaded products -- fresh or frozen.

Make the most of your energy dollars with our fully submersed element package. Heat absorption is maximized by full contact with the oil, allowing quick heat-up time and lower energy consumption per pound of product cooked.

Conserve expensive cooking oil - Dean's cool zone design minimizes wasteful oil deterioration by trapping debris under the cooking area, preventing carbonization of particles and oil contamination. The sloped bottom permits fast, easy draining of oil and sediment.

Enjoy fast recovery - Dean's snap action thermostat reacts quickly to changes in load conditions and helps eliminate loss of time incurred waiting between loads.

Make a smart investment - Dean's fryers achieve long and dependable life through simplicity of design with fully submersed elements that are safe and efficient. Shipped standard with stainless steel vessel, stainless steel front, aluminized sides, and legs.



ISO 9001:2000



SR14E Electric Fryer

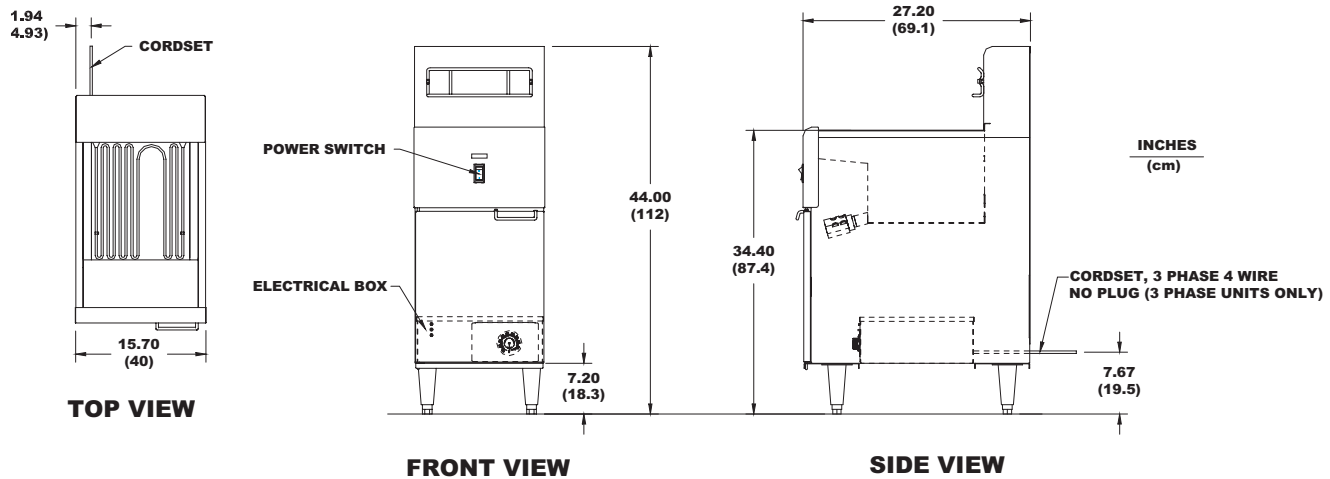

SPECIFICATIONS

Min./Max. Oil Capacity	Size (cm)				Drain Valve	Drain Valve Height	Frying Area	Shipping lbs./cu.ft.
	Width	Depth	Overall Height	Work Height				
35-40 lbs. (20-23 liters)	15.7" (40 cm)	27.20" (69 cm)	44" (112 cm)	34.4" (87 cm)	1.25" (3 cm)	23" (58.4 cm)	13.7" x 13.7" (35 x 35 cm)	180/15 82 kg/0,4

POWER REQUIREMENTS:

kW 14; 240 3 phase 3 wire (plus ground wire) 34 Amps
 kW 14; 208 3 phase 3 wire (plus ground wire) 39 Amps
 kW 14; 240 1 phase 2 wire (plus ground wire) 59 Amps
 kW 14; 208 1 phase 2 wire (plus ground wire) 68 Amps

SHORT FORM SPECIFICATION

Shall be DEAN free-standing cool zone deep fat fryer, Model SR14E. Only 15.7" (40 cm) wide, 35-40# (20-23 liters) oil capacity.

DEAN, whose policy is one of constant improvement, reserves the right to amend specifications without prior notice.

NOTES:

- To be field wired, no plug provided.
- All Canadian and single phase units sold without cordset.

STANDARD FEATURES

- Stainless steel fry vessel
- Stainless steel door and front, aluminized sides
- Basket hanger and two fry baskets
- 6" (15 cm) adjustable steel legs
- Drain extension

