



Job No. \_\_\_\_\_

Item No. \_\_\_\_\_

Quantity \_\_\_\_\_

## SM20G Gas Fryer - Millivolt Controls

## D20G Gas Fryers - Thermatron Solid State Controls

## Half-Size Fryers



SM20-2  
Shown w/optional casters

*Designed for small volume and add-on applications*

**Maximize your flexibility** - add a half-size fryer to an existing fryer or system. Only 7.75" (19.7 cm) wide, these compact units allow you to expand your fried foods menu.

**Fry a wide variety of products** - the half-size 6.75" x 14" (17 x 35 cm) fry area easily accommodates foods from appetizers to individual products, without flavor transfer.

**Make the most of your energy dollars** with our exclusive gas Thermo-Tube design. The heating tubes are surrounded by oil and heat absorption is maximized with controlled flow tube diffusers. The energy is forced into the oil with less going unused up the vent.

- Quick heat-up time relative to gas consumption.
- Low idle cost per hour during slow periods.
- Low gas consumption per load of product cooked.

**Minimize costly oil usage** - utilizes only 20-23 lbs. (11-13 L) of oil for optimum cooking efficiency. Plus, Dean's cool zone design reduces wasteful oil deterioration by trapping debris under the cooking area, preventing carbonization of particles and oil contamination. Sloped bottom and 1" (2.54 cm) drain valve makes cleaning fast and easy.

**Assure rapid recovery** - Dean's accurate thermostats eliminate time lost in waiting between loads. SM20G available with mechanical thermostat. D20 available with Thermatron solid state controls

**Build a system** - combine two or more units into a battery (combines with larger capacity units, too). Add optional filtration for safe and fast oil filtering

**Invest in a product built to last** - Dean fryers achieve long and dependable life through simplicity of design -- durable stainless steel diffusers and rugged cast iron burners keep maintenance to a minimum. Shipped standard with stainless steel front, door, and sides.



ISO 9001:2000



# SM20G - D20G Gas Fryers

## Half-Size Fryers

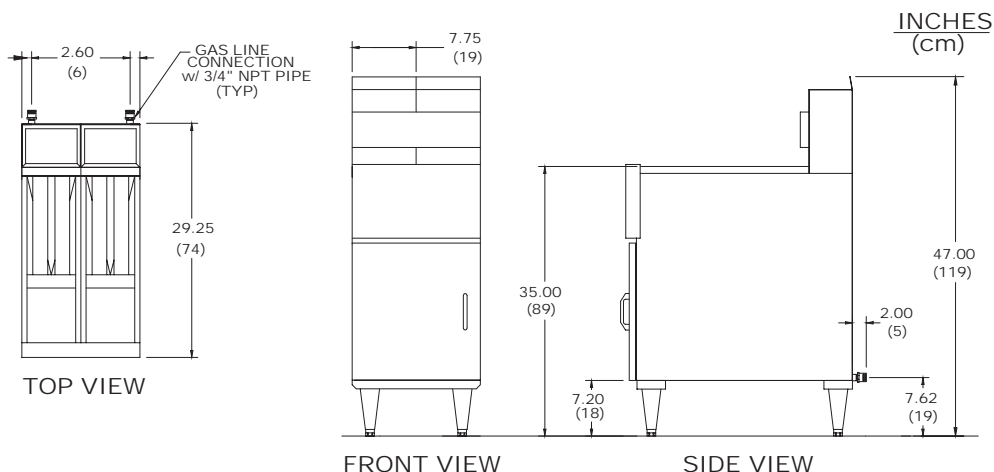

### SPECIFICATIONS

Model	Min/Max Oil Capacity	Width	Size (cm)			Drain Valve (cm)	Drain Valve Height (cm)	No. of Tubes	Frying Area (cm)	Shipping lbs./cu. ft. (kg/m <sup>3</sup> )
			Depth	Overall Height	Work Height					
SM20G	20-23 lbs. (11-13 L)	7.75" (19)	29.25" (74)	45" (114)	35" (89)	1" full flow (2.5)	20" (51)	2	6.75" x 14" (17 x 35)	115/15 (52/0,42)
D20G	20-23 lbs. (11-13 L)	7.75" (19)	29.25" (74)	45" (114)	35" (89)	1" full flow (2.5)	20" (51)	2	6.75" x 14" (17 x 35)	115/15 (52/0,42)

### POWER REQUIREMENTS

Model	Natural or LP Gas Gas Input Rating	Gas Connection	Electrical Requirement
SM20G	50,000 BTU (12,594 kcal) (14.6 kW)	3/4" N.P.T. regulator not required	NONE
D20G	50,000 BTU (12,594 kcal) (14.6 kW)	3/4" N.P.T. regulator not required	120V/60°/1Ø - 1.0A

Recommend 4 wire, 3 phase electrical connection.

### SHORT FORM SPECIFICATION

Shall be DEAN cool zone deep fat half-size fryer, Model \_\_\_\_\_. Only 7.75" (19 cm) wide, \_\_\_\_\_#oil capacity requiring \_\_\_\_\_ power with mechanical (SM20G) or solid state (D20G) controls. Not sold as a single free-standing unit.

DEAN, whose policy is one of constant improvement, reserves the right to amend specifications without prior notice.

### STANDARD FEATURES -- All Half-size Models

- Stainless steel frypot, front, door, and sides
- Basket hanger and one fry basket (5.50" x 6.31" x 12") (14 x 16 x 30 cm)
- Cool zone fry vessel construction
- Easily removable door for cleaning or servicing
- 6" (15 cm) adjustable steel legs
- **SM20G** - Millivolt pilot system - requires no electrical hook up
- **D20G**- Thermatron solid state controls



5489 Campus Drive, Shreveport, LA 71129, USA  
 Telephone: 318/865-1711 • Toll Free: 800/221-4583 • FAX: 318/868-5987  
<http://dean.enodis.com>

### ORDERING DATA

Gas - Please specify:  
 Natural or LP gas  
 Altitude -- if above 2000 ft. (610 m)  
 Electric - Please specify:  
 Voltage, cycle, phase

### DO NOT CURB MOUNT

### OPTIONS -- All Half-size Models

- Casters -- two units minimum
- Oil filtration system - see Super Cascade (UFF) spec sheets for details and additional electrical requirements

### D20G

- Automatic basket lifts - add 3.2A per fryer; add 1.50"(3 cm) to depth of fryer
- COMPU-FRY frying computer - must have two Half-Size fryers; add 1.0A per computer

Enodis  
 One Company. Countless Solutions

P/N 830-0048  
 Printed U.S.A. 11/04