



# Portable Filters

Project \_\_\_\_\_  
 Item \_\_\_\_\_  
 Quantity \_\_\_\_\_  
 CSI Section 11400 \_\_\_\_\_  
 Approval \_\_\_\_\_  
 Date \_\_\_\_\_

Portable Filters

## Models

PF50S

PF50R



## Standard Features

- 50-lb. capacity
- 4 GPM, 1/3 HP heavy-duty pump
- Fast - filters a 50-lb. fryer in 5 minutes
- Filters from bottom leaving minimal oil heel
- Stainless steel filter pan and pump assembly housing
- Cover and fold-down handle for safe and easy storage
- Steel frame mounted on four swivel casters allows for easy movement
- Suction line heated for solid shortening
- Nickel plated steel wand assembly with non-heat conducting handle for returning filtered oil to frypot
- Filter starter kit: filtration powder sample, 25 sheets filter paper, clean-out rod, cleaning brush

## Options & Accessories

Crumb tray

## Specifications

**Specifically designed to filter oil from any 50-lb Frymaster or Dean Fryer**

Frymaster portable filters are easy to use and are specifically designed to extend oil life by filtering out sediment and oil breakdown products, extending oil life and contributing to the consistent production of great tasting fried foods.

Standard 12" x 18" (305 x 457 mm) Filter Magic® filter paper and Filter Magic powder are required to effectively filter 50 lbs. of oil in five minutes from start to finish.

Independent heat keeps the suction line open and free flowing when solid shortening is used. The pump filters from the bottom so there is minimal oil heel left after filtration.

The PF50R model comes with a reversible pump which can be used to both remove oil and refill any manufacturer's 50-lb fryer.



ISO 9001:2000



8700 Line Avenue 71106  
P. O. Box 51000 71135-1000  
Shreveport, LA

Tel: 318-865-1711  
Tel: 1-800-221-4583  
Fax: 318-868-5987  
E-mail: [info@frymaster.com](mailto:info@frymaster.com)

[www.frymaster.com](http://www.frymaster.com)  
Bulletin No. 818-0092 11/07

Enodis®

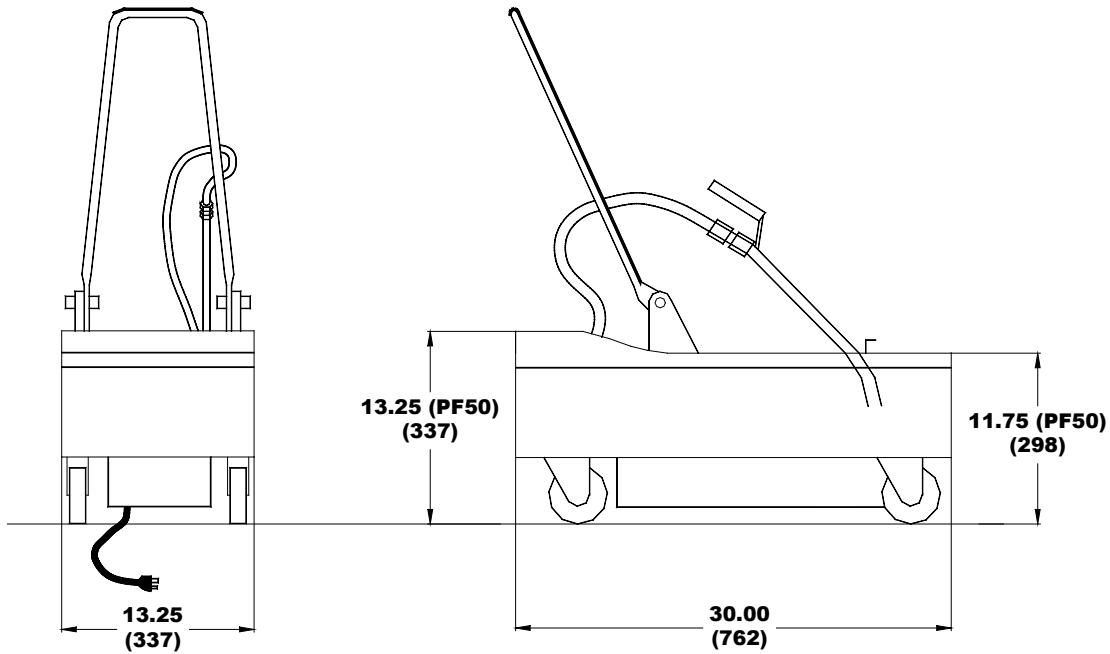

**PORTABLE FILTER (PF50 SHOWN)**

**DIMENSIONS**

MODEL NO.	SHORTENING CAPACITY	OVERALL SIZE (cm)			DRAIN HEIGHT	APPROXIMATE SHIPPING INFORMATION						
		HEIGHT	WIDTH	LENGTH		WEIGHT	CLASS	CU. FT.	DIMENSIONS			
PF50S and PF50R	50 lbs. (28 liters)	13.25" (337 mm)	13.25" (337 mm)	30" (762 mm)	11.75" (296 mm)	85 lbs. (39 kg)	85	7.63	<b>H</b> 25" (635 mm)	<b>W</b> 16.75" (425 mm)	<b>L</b> 31.50" (800 mm)	

Hose is 66-1/2" (1689 mm) long, wand is 25" (635 mm) long.  
Cord is 61" (1549 mm) long.

**POWER REQUIREMENTS**

- 1/3 H.P., 120V - 60 Hz 9 Amp
- 230 VAC 50 Hz. 5 Amp

**NOTES**

Filters 50-lbs. of liquid shortening in 5 minutes. Independent heat control keeps piping open and free flowing when solid shortening is used.

**HOW TO SPECIFY**

- PF50S 50-lb. capacity standard, gravity drain
- PF50R 50 lb. capacity, reversible pump