



Topping Equipment Dry Product Dispensers

Model DPD

Date:

Project:

Quantity:

Item Number:



DPD 1-Liter Single #86670 (left)
DPD 2-Liter Single #86680 (right)



Bid Description

The Dry Product Dispenser is a hopper system that accurately portions powders and other dry products. The dispenser allows portions from ¼ to 2-ounces (7 to 60 mL) by volume and is adjustable in ⅛-ounce (3.4 mL) increments. Suggestions for use include smoothie powders, iced coffee powders, mix-ins for blended ice cream drinks and cocktail powders.

Dry Product Dispensers are designed to be mounted side by side for a station of several products. Choose from 1 or 2-liter capacity models with a single, double or triple wall bracket.

A guideline for product use would be as long as it is consistent and not much bigger than ½-inch (1.3 cm) in diameter. Very fine or dissimilar products as well as those that tend to melt or stick together at room temperature are not recommended. Examples include protein and malt powders or crushed candy bars.

Standard Features

Durable, clear polycarbonate hopper shows off product

Accurately dispense dry products of a consistent material

Dispense between ¼ and 2-oz (7 and 60 mL) by volume

Adjust portions in ⅛-oz (3.4 mL) increments

No need to worry about accidental portion changes; disassembly is necessary for portion adjustment

Takes up just 5 linear inches (12.7 cm) of wall space and includes handy wall mount bracket

Silicone sleeve at end of discharge tube removes for cleaning



Warranty

Server Products equipment is backed by a two-year limited warranty against defects in materials and workmanship. For our complete warranty statement, see our Website or contact us.

Specifications on reverse side



Topping Equipment Dry Product Dispensers

Model DPD

Dry Food Dispensers

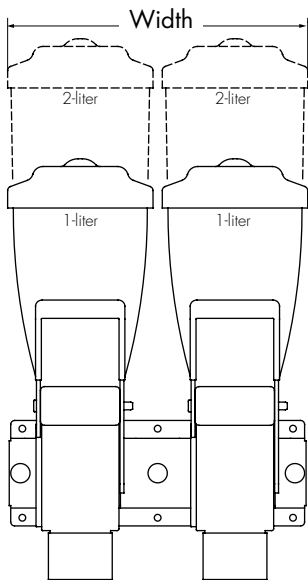
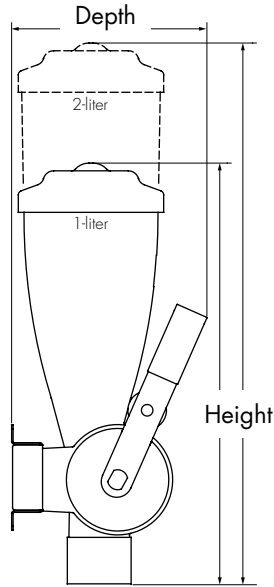

Specifications

DPD Models	Single #86670	Double #86690	Triple #86650
Height	in 13 ⁹ / ₁₆ cm 34.5	in 13 ⁹ / ₁₆ cm 34.5	in 13 ⁹ / ₁₆ cm 34.5
Width	in 4 ¹¹ / ₁₆ cm 11.9	in 9 ¹¹ / ₁₆ cm 24.6	in 14 ¹¹ / ₁₆ cm 37.3
Depth	in 6 ⁵ / ₁₆ cm 16	in 6 ⁵ / ₁₆ cm 16	in 6 ⁵ / ₁₆ cm 16
Capacity	1 Liter	1 Liter	1 Liter
Ship Wt.	lb 5 kg 2.3	lb 9 kg 4.1	lb 11 kg 5

DPD Models	Single #86680	Double #86640	Triple #86660
Height	in 17 ⁷ / ₁₆ cm 44.3	in 17 ⁷ / ₁₆ cm 44.3	in 17 ⁷ / ₁₆ cm 44.3
Width	in 4 ¹¹ / ₁₆ cm 11.9	in 9 ¹¹ / ₁₆ cm 24.6	in 14 ¹¹ / ₁₆ cm 37.3
Depth	in 6 ⁵ / ₁₆ cm 16	in 6 ⁵ / ₁₆ cm 16	in 6 ⁵ / ₁₆ cm 16
Capacity	2 Liter	2 Liter	2 Liter
Ship Wt.	lb 5 kg 2.3	lb 9 kg 4.1	lb 12 kg 5.4

FOB Richfield, Wisconsin 53076

CAD Library

Individual CAD images can be downloaded from product pages on our website. We are also a member of The KCL CADalog with more than 100 other manufacturers. Our complete collection of CAD files can be purchased through Kochman Consultants, Ltd. at www.kclcad.com.

