



FOOD WARMERS {FOOD SERVERS} TWIN & TRIPLE WELL

Models Twin FS-4
Triple FS-4

Date:

Project:

Quantity:

Item Number:



Twin FS-4 81200



ALSO AVAILABLE FOR EXPORT



Triple FS-4 85900



Warranty

Server Products equipment is backed by a two-year limited warranty against defects in materials and workmanship. For a copy of our complete warranty statement, see our web site or contact us.

Bid Description

The twin and triple food servers are water bath warmer/cookers constructed of stainless steel with a brushed (#4) finish. Inset and lid assemblies are included. Hinged lids stay upright during ladling and feature a rim that collects moisture and returns it to the food. Insets have a 4 quart (3.8 L) capacity each. Power is controlled with individual ON/OFF rocker switches for each food vessel.

Adjustable precalibrated thermostats control individual 500 watt heating elements. Temperature settings—marked on thermostat knobs—range from 100° F (38° C) to 200° F (93° C).

Standard Features

- All stainless steel construction for durability
- NSF-certified as a rethermalization unit
- Lid rim returns moisture to the food to retain flavor
- Hinged lids stay upright during ladling for easy customer use
- Adjustable precalibrated thermostats for accurate heat control
- Temperature marks on knobs with protective knob guards
- Water fill lines eliminate overflow accidents

Accessories

- 4 qt (3.8 L) Inset & Lid Assembly 81050
- 2 oz (59 mL) Ladle 82660
- 4 oz (118 mL) Ladle 82574
- 6 oz (177 mL) Ladle 82661
- 8 oz (237 mL) Ladle 82662

Specifications on reverse side



FOOD WARMERS {FOOD SERVERS} TWIN & TRIPLE WELL

Models Twin FS-4

Triple FS-4

Food Servers

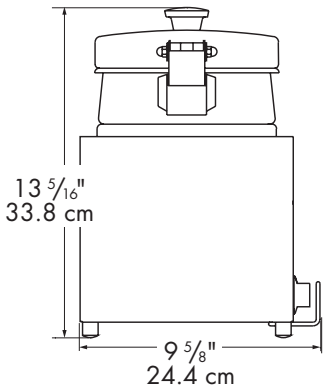
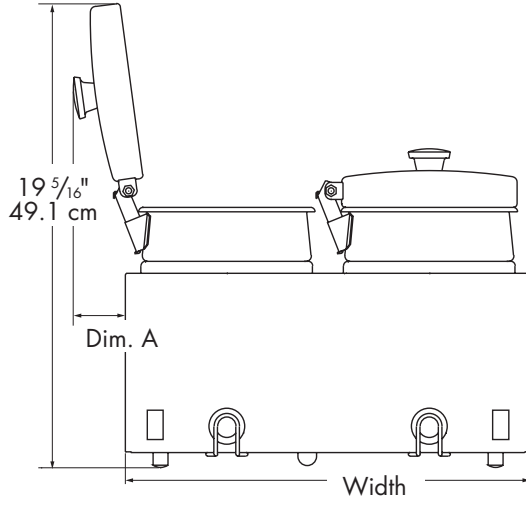

Specifications

Model	Twin FS-4 81200															
Construction	All stainless steel with a brushed (#4) finish. Complete with (2) insets and lid assemblies.															
Capacity	(2) insets hold 4-qt (3.8 L) each; 8-qt (7.6 L) total.															
Dimensions	<table border="1"> <thead> <tr> <th></th> <th>Height</th> <th>Width</th> <th>Depth</th> <th>Dim. A</th> </tr> </thead> <tbody> <tr> <td>in</td> <td>13 ⁵/₁₆</td> <td>17</td> <td>9 ⁵/₈</td> <td>2 ³/₁₆</td> </tr> <tr> <td>cm</td> <td>33.8</td> <td>43.2</td> <td>24.4</td> <td>5.6</td> </tr> </tbody> </table> Height with lid open: 19 ⁵ / ₁₆ " (49.1 cm)		Height	Width	Depth	Dim. A	in	13 ⁵ / ₁₆	17	9 ⁵ / ₈	2 ³ / ₁₆	cm	33.8	43.2	24.4	5.6
	Height	Width	Depth	Dim. A												
in	13 ⁵ / ₁₆	17	9 ⁵ / ₈	2 ³ / ₁₆												
cm	33.8	43.2	24.4	5.6												
Electrical	120V, 60Hz, 1000W, 8.3A 72 in (183 cm) cord set NEMA 5-15P, 15A, 125V PLUG															
Ship Weight	20 lb (9.1 kg)															
Model	Triple FS-4 85900															
Capacity	Same as above except: (3) insets hold 4 qt (3.8 L) each; 12 qt (11.4 L) total.															
Dimensions	<table border="1"> <thead> <tr> <th></th> <th>Height</th> <th>Width</th> <th>Depth</th> <th>Dim. A</th> </tr> </thead> <tbody> <tr> <td>in</td> <td>13 ⁵/₁₆</td> <td>25 ¹/₂</td> <td>9 ⁵/₈</td> <td>2 ³/₁₆</td> </tr> <tr> <td>cm</td> <td>33.8</td> <td>64.8</td> <td>24.4</td> <td>5.6</td> </tr> </tbody> </table> Height with lid open: 19 ⁵ / ₁₆ " (49.1 cm)		Height	Width	Depth	Dim. A	in	13 ⁵ / ₁₆	25 ¹ / ₂	9 ⁵ / ₈	2 ³ / ₁₆	cm	33.8	64.8	24.4	5.6
	Height	Width	Depth	Dim. A												
in	13 ⁵ / ₁₆	25 ¹ / ₂	9 ⁵ / ₈	2 ³ / ₁₆												
cm	33.8	64.8	24.4	5.6												
Electrical	120V, 60Hz, 1500W, 12.5A															
Weight	28 lb (12.7 kg)															

FOB Richfield, Wisconsin 53076

NSF Listed as a rethermalization unit to ensure food is quickly heated to a safe temperature before bacteria has an opportunity to grow.

CAD Library

Individual CAD images can be downloaded from product pages on our web site. We are also a member of The KCL CADalog with more than 100 other manufacturers. Our complete collection of CAD files can be purchased through Kochman Consultants, Ltd. at kclcad.com.

