



Food Warmers Supreme™ Food Server

Model FSPWI-11SS

Date:

Project:

Quantity:

Item Number:



FSPWI-11SS #85280



NSF-certified as a rethermalization unit



Warranty

Server Products equipment is backed by a two-year limited warranty against defects in materials and workmanship. For a copy of our complete warranty statement, see our Website or contact us.

Bid Description

Server Supreme™ water bath warmer is constructed of brushed (#4) finish stainless steel shroud with a black thermoset plastic bottom and top. A spout warmer, on the instrument panel side, permits safe dispensing of potentially hazardous foods. The 1500-watt heating element is controlled by an adjustable, precalibrated thermostat. Set thermostat by temperature settings.

Stainless steel pump features a cast valve body designed to prevent loss of valve balls and welded construction. Maximum stroke is 1-ounce (30 mL) with gauging collars supplied to reduce the yield in 1/4-ounce (7 mL) increments.

Complete with an exclusive 8-quart (7.6 L) stainless steel inset, the FSPWI-11SS features a "Power On" light, adjustable leveling legs, water fill line and removable probe thermometer. NSF-Listed for rethermalization and potentially hazardous foods.

Standard Features

High wattage provides fast efficient heating

Maximum pump stroke yields 1-ounce (30 mL) with portion control in 1/4-ounce (7 mL) increments

Pump design prevents loss of valve balls

Spout warmer permits safe dispensing of potentially hazardous foods such as cheese and gravies

Adjustable precalibrated thermostat for accurate heat control

Water fill line eliminates overflow accidents

Probe thermometer constantly monitors product temperature for convenient food safety monitoring

Adjustable legs aid user in leveling unit on uneven surfaces

Two cleaning brushes included for pump maintenance



Food Warmers Supreme™ Food Server

Model FSPWI-11SS

Supreme™ Server with Spout Wamer and Pump

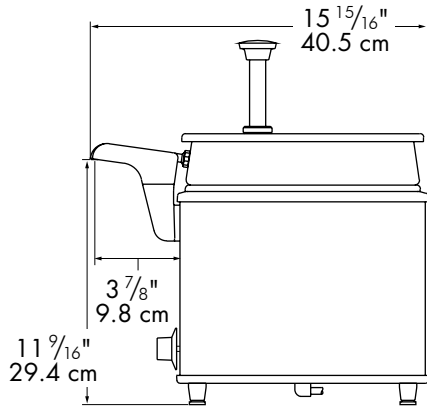
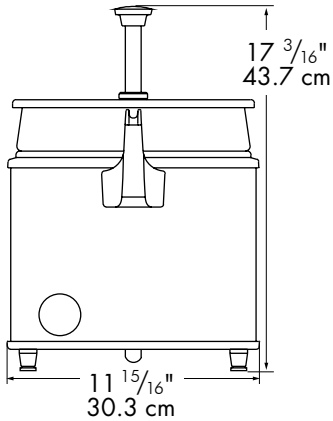

Specifications

Model	FSPWI-11SS #85280				
Construction	Stainless steel with black ABS plastic top & bottom. Includes stainless steel food vessel.				
Capacity	8-quart (7.6 L)				
Dimensions	<u>Height</u>	<u>Width</u>	<u>Depth</u>	<u>Dim. A</u>	
	in	17 ³ / ₁₆	11 ¹⁵ / ₁₆	15 ¹⁵ / ₁₆	3 ⁷ / ₈
	cm	43.7	30.3	40.5	9.8
Electrical	120V, 60Hz, 1515W, 12.6 A 72 in (183 cm) cord set NEMA 5-15P, 15A, 125V PLUG				
Ship Weight	22 lb (10 kg)				

FOB Richfield, Wisconsin 53076

CAD Library

We are a member of The KCL CADalog with more than 100 other manufacturers. Our CAD files can be purchased through Kochman Consultants, Ltd. at 847-470-1195 or e-mail sales@kclcad.com. Their Website is at www.kclcad.com.

