



Condiment Units Condiment Dispensers

Models CP-F
CP-200

Date:

Project:

Quantity:

Item Number:



CP-F #83330
(jar not included)



CP-200 #83300
(jar not included)



Warranty

Server Products equipment is backed by a two-year limited warranty against defects in materials and workmanship. For our complete warranty statement, see our Web site or contact us.

Bid Description

Constructed of stainless steel, each condiment pump features a rugged cast valve body and welded construction. A pump and jar drop into a counter or can be placed into a Serving Bar. An insulated Serving Bar can be cooled with ice, one Eutectic Ice Pack per pump or our deep fountain HOLDCOLD™ jars. HOLDCOLD™ jars will maintain serving temperature up to twelve hours, when used properly.

The CP-F will pump condiments from a deep fountain jar. Maximum stroke yields 1 1/4-ounce (37 mL). Gauging collars are supplied to reduce yield in 1/4-ounce (7 mL) increments.

The CP-200 is designed to pump condiments from a standard shallow fountain jar. Maximum stroke yields 1-ounce (30 mL) with gauging collars supplied to reduce yield in 1/4-ounce (7 mL) increments.

Standard Features

Durable, stainless steel construction

CP-F; maximum stroke yields 1 1/4-ounce (37 mL)

CP-200; maximum stroke yields 1-ounce (30 mL)

Easy-to-adjust portion control in 1/4-ounce (7 mL) increments

Two cleaning brushes included for pump maintenance

Colored, engraved knobs to identify flavors are available upon request. For options, contact our customer service department.

Condiment Dispenser Accessories

- Fountain Jar, deep—Stainless Steel #82555
- Fountain Jar, deep—Polypropylene #82557
- Fountain Jar, deep—HOLDCOLD™, Black #82632
- Fountain Jar, deep—HOLDCOLD™, White #82633
- Kit, HOLDCOLD™ Jars—1 White & 1 Black #82634
- Fountain Jar, shallow—Stainless Steel #82556
- Fountain Jar, shallow—Polypropylene #82558
- Pump Lock #80443
- Eutectic Ice Pack #94141

Specifications on reverse side

Condiment Pump CP-F #83330

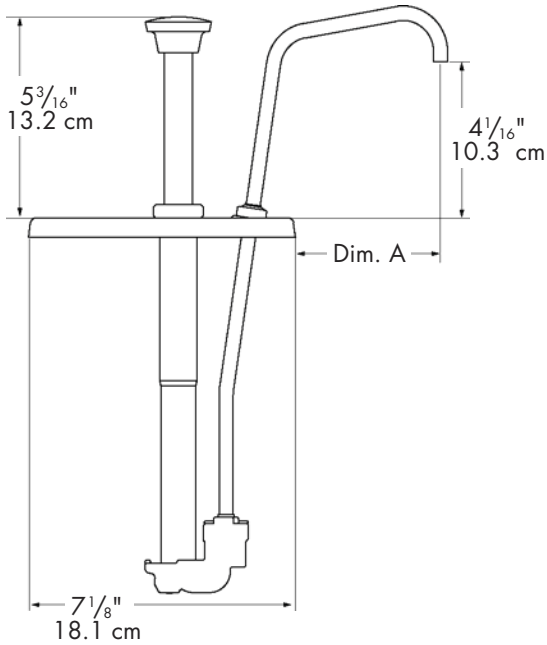

Condiment Pump CP-200 #83300

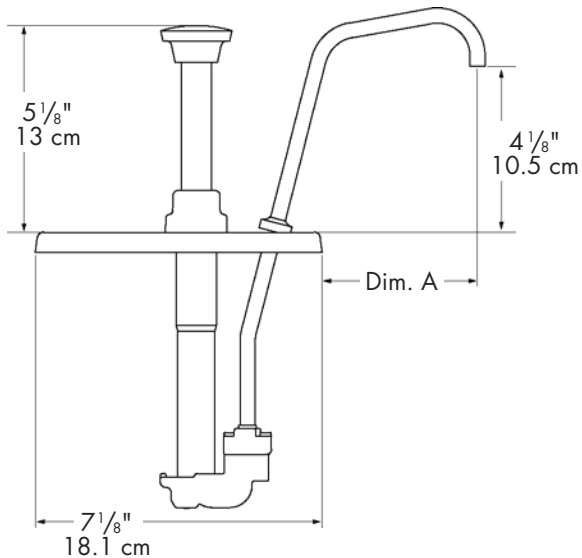

Specifications

Model	CP-F #83330			
Construction	Stainless steel pump with cast valve body and welded construction fits a deep fountain jar.			
Capacity	Standard deep fountain jar has a 3½-quart (3.3 L) capacity. A HOLDCOLD™ deep fountain jar has a 2¼-quart (2.1 L) capacity.			
Dimensions (above jar)	<u>Height</u>	<u>Width</u>	<u>Depth</u>	<u>Dim. A</u>
	in 5 3/16	4 ½	7 1/8	3 7/8
	cm 13.2	11.4	18.1	9.8
Ship Weight	3 lb (1.4 kg)			
Cutout Size	4 5/16 x 7 in (11 x 17.8 cm)			
Model	CP-200 #83300			
	Same as above except:			
Construction	Fits a shallow fountain jar.			
Capacity	2-quart (1.9 L) capacity			
Dimensions (above jar)	<u>Height</u>	<u>Width</u>	<u>Depth</u>	<u>Dim. A</u>
	in 5 1/8	4 ½	7 1/8	3 7/8
	cm 13	11.4	18.1	9.8

FOB Richfield, Wisconsin 53076

CAD Library

We are a member of The KCL CADalog with more than 100 other manufacturers. Our CAD files can be purchased through Kochman Consultants, Ltd. at 847-470-1195, or e-mail sales@kclcad.com. Their Web site is at www.kclcad.com.