



Condiment Units Express Center™

Models
EC
EC-TWIN

Date:

Project:

Quantity:

Item Number:



EC #07130



EC-TWIN #07120

Bid Description

The Express Center™ is constructed of a brushed finish stainless steel base. The front section is furnished with a Server Express™ System—a surgical-quality plastic, five-piece condiment pump in a black thermoset polyester vessel. Pump vessel lid is polished stainless steel. The back section includes a Serve-A-Cup™ soufflé cup dispenser which is constructed of a polypropylene cup tube. Complete with a two-year warranty.

The Express™ System capacity is 1½ gallons (or 6 L). Maximum stroke yields 1-ounce (30 mL). Portion control reduces the yield in ¼-ounce (7 mL) increments. NSF listed unit exclusively uses a Cryovac® pouch with fitment and achieves up to 98% evacuation.

The Serve-A-Cup™ includes cup guides and strippers to dispense ¾- and 1-ounce (22-, 30 mL) paper or plastic soufflé cups one-at-a-time. Capacity is approximately 100 paper cups. This model can be adapted to hold six soufflé cup sizes: ¾-, 1-, 1¼-, 1½-, 2-, and 2½-ounces (22-, 30-, 37-, 45-, 60-, and 75-mL). Contact our customer service department for details.

The Twin Express Center consists of a brushed finish stainless steel base furnished with two Server Express™ Systems and two Serve-A-Cup™ soufflé cup dispensers as described above.

Standard Features

Pump vessel holds a 1½-gallon (or 6 L) Cryovac® pouch

Pump has five surgical-quality plastic parts—quick to breakdown and completely dishwasher safe

Two discharge fittings—black for ketchup and mustard, white for thicker products

One-at-a-time cup dispensing reduces waste and contamination



Dispenses ¾- and 1-ounce (22-, 30 mL) paper or plastic cups

Easily dispense approx. 100 or 200 paper soufflé cups while keeping your condiment serving area neat and clean

Warranty

Server Products equipment is backed by a two-year limited warranty against defects in materials and workmanship. For a copy of our complete warranty statement, see our website or contact us.

Express Center™ Accessories

- Tapered Discharge Fitting #07119
- Replacement Pump #07044
- Decal Set    #07131



Specifications on reverse side

SERVER

Condiment Units Express Center™

Models
EC
EC-TWIN

Express Center™ EC #07130

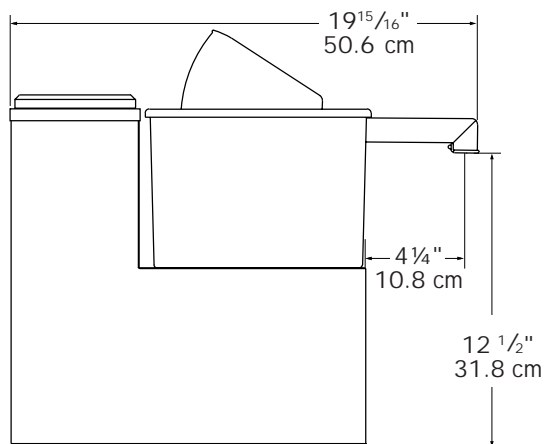
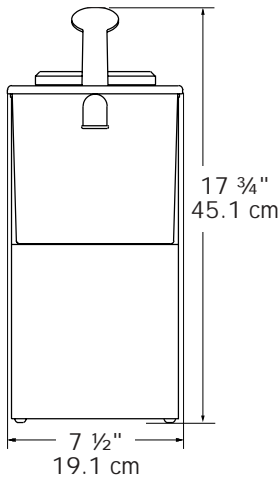

Express Center-Twin™ EC-TWIN #07120

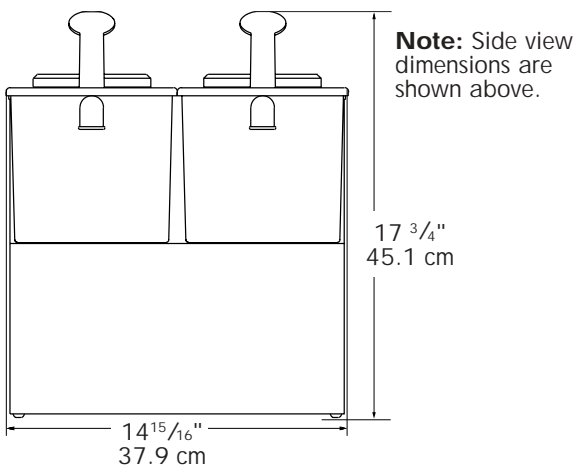

Specifications

Model	EC #07130		
Construction	Stainless steel base with brushed finish. Includes surgical-quality plastic pump, black thermoset polyester vessel, and polypropylene (tube) soufflé cup dispenser. Pump vessel lid is polished stainless steel.		
Capacity	1½-gallon (or 6 L) capacity		
Dimensions	<u>Height</u>	<u>Width</u>	<u>Depth</u>
	in 17 ¾	7 ½	19 15/16
	cm 45.1	19.1	50.6
Ship Weight	16 lb (7.3 kg)		
Model	EC-TWIN #07120		
Construction	Same as above except:		
Capacity	1½-gallon (or 6 L) capacity per pump vessel– 3-gallons (or 12 L) total		
Dimensions	<u>Height</u>	<u>Width</u>	<u>Depth</u>
	in 17 ¾	14 15/16	19 15/16
	cm 45.1	37.9	50.6
Ship Weight	26 lb (11.8 kg)		

Cryovac® is a registered trademark and a trade name of Cryovac Inc.

FOB Richfield, Wisconsin 53076

CAD Library

We are a member of The KCL CADalog with more than 100 other manufacturers. Our CAD files can be purchased through Kochman Consultants, Ltd. at 847-470-1195, or e-mail sales@kclcad.com. Their Website is at www.kclcad.com.



Server Products, Inc. • P.O. Box 98 • Richfield, WI 53076 • Toll Free: 800-558-8722
Phone: 262-628-5600 • Fax: 262-628-5110 • pumps@execpc.com • www.server-products.com

Server Products, Inc. reserves the right to modify specifications without obligation. Printed in U.S.A.

8:2002/4M Stock #02062